

13V,10A全集成同步升压转换器

13V,10A Fully-Integrated Synchronous Boost Converter

■ FEATURES

- Input voltage range V_{IN} : 2.7V to 13V
 - Output voltage range V_{OUT} : 4.5V to 13V
 - Switch peak current limit: 10A
 - High Efficiency
93% ($V_{IN} = 7.4V, V_{OUT}=12V, I_{OUT} = 3A$)
92% ($V_{IN} = 3.6V, V_{OUT}=9V, I_{OUT} = 1A$)
 - 1.0 μ A current consumption during shutdown
 - Fixed switching frequency: ~450kHz
 - Output overvoltage protection (at 14V), cycle-by-cycle overcurrent protection, thermal shutdown protection
 - Pb-free Packages, ESOP10
- 输入电压范围 V_{IN} : 2.7V-13V
 - 输出电压范围 V_{OUT} : 4.5V-13V
 - 内部固定峰值电流: 10A
 - 高转换效率:
93% ($V_{IN} = 7.4V, V_{OUT}=12V, I_{OUT} = 3A$)
92% ($V_{IN} = 3.6V, V_{OUT}=9V, I_{OUT} = 1A$)
 - 低关断功耗, 关断电流1 μ A
 - 内部固定开关频率: ~450kHz
 - 输出过压 (14V)、逐周期过流、热关断等保护
 - ESOP10, 无铅封装

■ APPLICATIONS

- Wireless/ Speakers
- Portable Speakers
- Quick Charge Power Bank
- E-Cigarette
- Power Interface (USB Type-C, Thunderbolt)
- POS Terminal
- Tablet PC/Note Book
- 无线音箱
- 便携式音箱
- 快充移动电源
- USB TYPE-C 电源传输
- 平板电脑, 笔记本电脑
- 电子烟
- 拉杆音箱
- POS机终端

DESCRIPTION

The HT71663 is a high-power density, fully integrated synchronous boost converter with a 16mΩ power switch and a 23mΩ rectifier switch to provide a high efficiency and small size solution in portable systems. The HT71663 has wide input voltage range from 2.7 V to 13 V to support applications with single cell and two cell Lithium batteries. The device has 10A switch current capability and can provide an output voltage up to 13V.

The HT71663 uses adaptive constant off-time peak current control topology to regulate the output voltage. In moderate to heavy load condition, it works in the PWM mode. In light load condition, the device operates in PFM mode to improve the efficiency. The switching frequency in the PWM mode is fixed.

In addition, the device provides 14V output overvoltage protection, cycle-by-cycle overcurrent protection, and thermal shutdown protection.

HT71663是一款高功率、全集成升压转换器,集成16mΩ功率开关管和23mΩ同步整流管,为便携式系统提供高效的小尺寸解决方案。

HT71663具有2.7V至13V宽输入电压范围,可为采用单节或两节锂电池的应用提供支持。该器件具备10A开关电流能力,并且能够提供最高13V的输出电压。

HT71663采用自适应恒定关断时间峰值电流控制拓扑结构来调节输出电压。在中等到重载条件下,HT71663工作在PWM模式。在轻负载条件下,该器件工作在可提高效率的PFM模式。

此外,该器件还提供有14V输出过压保护、逐周期过流保护和热关断保护。

TYPICAL APPLICATION

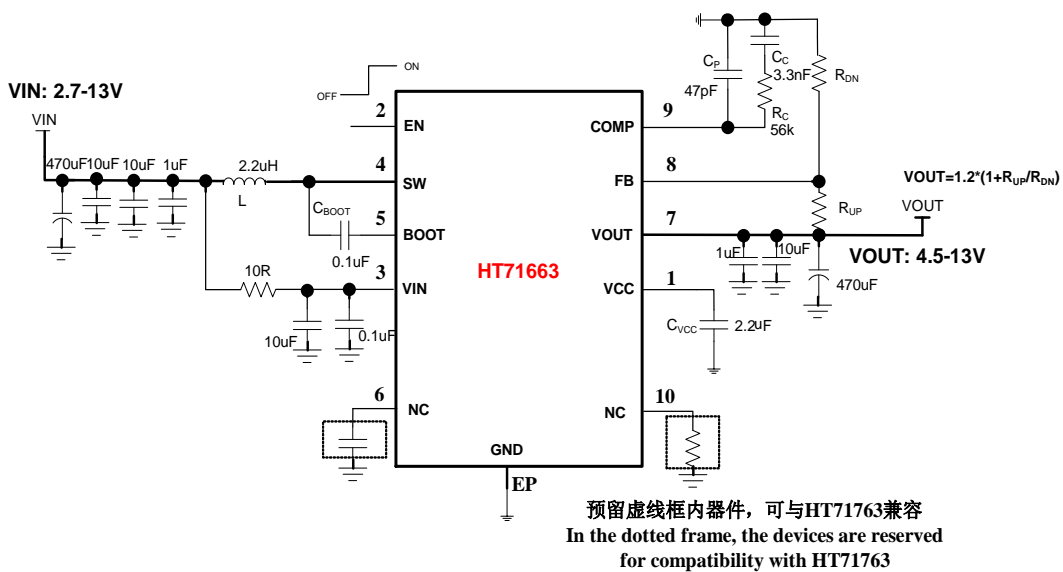

ORDERING INFORMATION

| Part Number | Package Type | Package Abbr. | Marking | Shipping Package / MOQ |
|-------------|--------------|---------------|---------------------------------|------------------------|
| HT71663SPER | ESOP10 | SPE | HT71663 YYYMAAB ¹ | Tape and Reel / 2500 |

Part Number

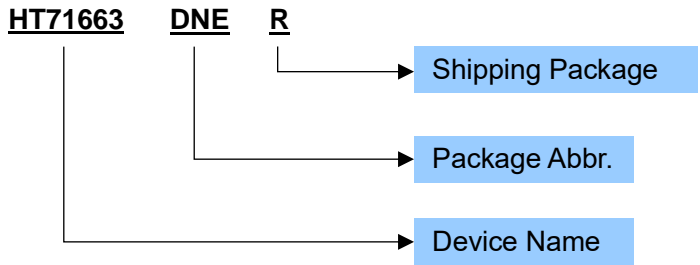

Production Tracking Code

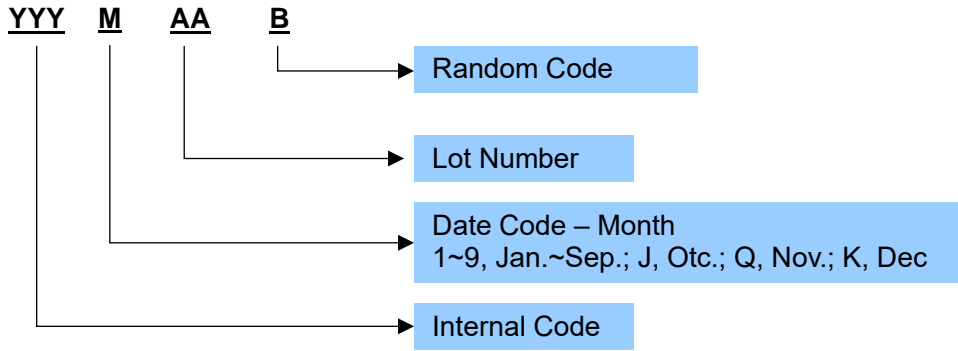

¹ YYYMAAB is production tracking code
Copyright©2024, Heroic Technology

■ TERMINAL CONFIGURATION

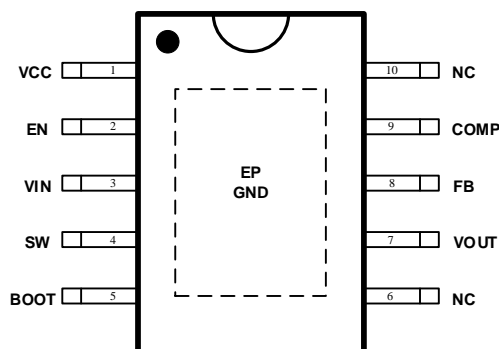

Top View

■ TERMINAL FUNCTION

| Terminal No. | Name | I/O ¹ | Description |
|--------------|------|------------------|---|
| 1 | VCC | O | Output of the internal regulator. A ceramic capacitor of 2.2uF is required between this pin and ground. 接2.2uF到地。 |
| 2 | EN | I | Enable logic input. Logic high level enables the device. Logic low level disables the device and turns it into shutdown mode. 使能输入，接高电平使能，低电平关断 |
| 3 | VIN | P | IC power supply input. 电源输入脚 |
| 4 | SW | P | The switching node pin of the converter. 升压开关节点 |
| 5 | BOOT | O | Power supply for high-side MOSTFET gate driver. A ceramic capacitor of 0.1uF must be connected between this pin and the SW pin. 接0.1uF电容到SW |
| 6, 10 | NC | - | No connection, connect to GND. 内部无连接，可连接到地。 |
| 7 | VOUT | P | Boost converter output. 升压输出 |
| 8 | FB | I | Voltage feedback. 电压反馈 |
| 9 | COMP | O | Output of the internal error amplifier, the loop compensation network should be connected between this pin and the AGND pin. 接阻容补偿网络到地。 |
| EP | GND | G | Provides both electrical and thermal connection from the device to the board. A matching ground pad must be provided on the PCB and the device connected to it via solder. For proper electrical operation, this ground pad must be connected to the system ground. 既是地，又是散热PAD |

¹ I: Input; O: Output; G: Ground; P: Power; BST: BOOT Strap; OD: Open drain

■ SPECIFICATIONS¹

● Absolute Maximum Ratings²

| PARAMETER | | Symbol | MIN | MAX | UNIT |
|--------------------------------------|--|------------------|------|------|------|
| Voltage range | BOOT | / | -0.3 | SW+7 | V |
| | EN, SW, V _{OUT} , V _{IN} | | -0.3 | 14.2 | |
| | VCC, COMP | | -0.3 | 7 | |
| | FB | | -0.3 | 3.6 | |
| Operating temperature range | | T _A | -40 | 85 | °C |
| Operating junction temperature range | | T _J | -40 | 150 | °C |
| Storage temperature range | | T _{STG} | -50 | 150 | °C |

● Recommended Operating Conditions

| PARAMETER | Symbol | CONDITION | MIN | TYP | MAX | UNIT |
|-------------------------------------|------------------|-----------|------|-----|------|------|
| IC power supply voltage range | V _{IN} | | 2.7 | | 13.2 | V |
| Output voltage range | V _{OUT} | | 4.5 | | 13.8 | V |
| Inductance, effective value | L | | 0.47 | 2.2 | 10 | μH |
| Input capacitance, effective value | C _I | | 10 | | | μF |
| Output capacitance, effective value | C _O | | 6.8 | 47 | 1000 | μF |
| Operating temperature | T _a | | -40 | 25 | 85 | °C |
| Operating junction temperature | T _J | | -40 | | 125 | °C |

¹ Depending on parts and PCB layout, characteristics may be changed.

² Stresses beyond those listed under absolute maximum ratings may cause permanent damage to the device. These are stress ratings only, and functional operation of the device at these or any other conditions beyond those indicated under recommended operating conditions is not implied. Exposure to absolute-maximum-rated conditions for extended periods may affect device reliability.

● **Electrical Characteristics¹**

Condition: Ta = 25°C, VIN = 2.7V-13.2V, VOUT=4.5-13.2V, unless otherwise specified.

Power Supply

| PARAMETER | Symbol | CONDITION | MIN | TYP | MAX | UNIT |
|--|----------|--|-----|------|------|------|
| Input power voltage range | VIN | | 2.7 | | 13.2 | V |
| IC power supply voltage range | VIN | | 2.7 | | 13.2 | V |
| Under-voltage lockout (UVLO) threshold | VIN_UVLO | VIN rising | | 2.5 | | V |
| | | VIN falling | | 2.3 | | V |
| VIN UVLO hysteresis | VIN_HYS | | | 200 | | mV |
| VCC UVLO threshold | VCC_UVLO | | | 2.1 | | V |
| Operating quiescent current from VIN | IQ | IC enabled, no load, VFB = 1.3V, VOUT = 12V | | 1 | | uA |
| Operating quiescent current from VOUT | | | | 150 | | |
| Shutdown current into VIN | ISD | IC disabled, no load, no feedback resistor divider | | 1 | | uA |
| VCC regulation | VCC | VIN = 4.0V, VOUT = 12V, light load | | 5.3 | | V |
| | | VIN = 4.0V, VOUT = 12V, ILOAD = 1A | | 5.05 | | V |

EN and EMI Input

| PARAMETER | Symbol | CONDITION | MIN | TYP | MAX | UNIT |
|----------------------------------|--------|-----------|-----|------|-----|------|
| EN high threshold voltage | VENH | | | | 1.2 | V |
| EN low threshold voltage | VENL | | 0.4 | | | V |
| EN internal pull-down resistance | REN | | | 1300 | | kΩ |

OUTPUT

| PARAMETER | Symbol | CONDITION | MIN | TYP | MAX | UNIT |
|---------------------------------|--------|-----------|------|-------|------|------|
| Output voltage range | VOUT | | 4.5 | | 13.2 | V |
| Output overvoltage protection | VOVP | | | 14.4 | | V |
| Reference voltage at the FB pin | VREF | | 1.17 | 1.204 | 1.23 | V |
| Soft-start charging current | ISS | | | 5 | | uA |

ERROR AMPLIFIER

| PARAMETER | Symbol | CONDITION | MIN | TYP | MAX | UNIT |
|------------------------------------|---------|-----------------------------------|-----|------|-----|------|
| COMP pin sink current | ISINK | VFB = VREF +200 mV, VCOMP = 1.5 V | | 20 | | uA |
| COMP pin source current | ISOURCE | VFB = VREF -200 mV, VCOMP = 1.5 V | | 20 | | uA |
| High clamp voltage at the COMP pin | VCC_LPH | VFB = 1 V, RILIM = 100 kΩ | | 2.14 | | V |
| Low clamp voltage at the COMP pin | VCC_LPL | VFB = 1.5 V, RILIM = 100 kΩ, | | 0.94 | | V |
| Error amplifier transconductance | GEA | VCOMP = 1.5 V | | 204 | | uA/V |

¹ Depending on parts and pattern layout, characteristics may be changed

| PARAMETER | Symbol | CONDITION | MIN | TYP | MAX | UNIT |
|-----------------------------------|---------------------|--|-----|-------|-----|------|
| POWER SWITCH | | | | | | |
| MOSFET on-resistance | R _{DS(on)} | High-side MOSFET | | 23 | | mΩ |
| | | Low-side MOSFET | | 16 | | mΩ |
| CURRENT LIMIT | | | | | | |
| Peak switch current limit | I _{LIM} | | | 10 | | A |
| Reference voltage at the ILIM pin | V _{ILIM} | | | 1.204 | | V |
| SWITCHING FREQUENCY | | | | | | |
| Switching frequency | f _{SW} | V _{IN} = 3.7V, V _{OUT} = 12V | | 430 | | kHz |
| Minimum on-time | t _{ON_min} | V _{IN} = 3.6V, V _{OUT} = 12V | | 490 | | ns |
| THERMAL SHUTDOWN | | | | | | |
| Thermal shutdown threshold | T _{SD} | | | 160 | | °C |
| Thermal shutdown hysteresis | T _{SD_HYS} | | | 20 | | °C |

TYPICAL OPERATING CHARACTERISTICS

Condition: L = 2.2uH, Output Capacitor = 1uF//10uF//10uF//220uF, otherwise specified.

Shutdown Current

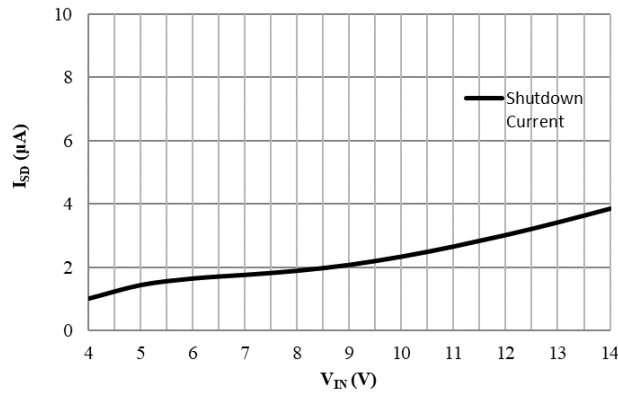

I_{OUT} vs η

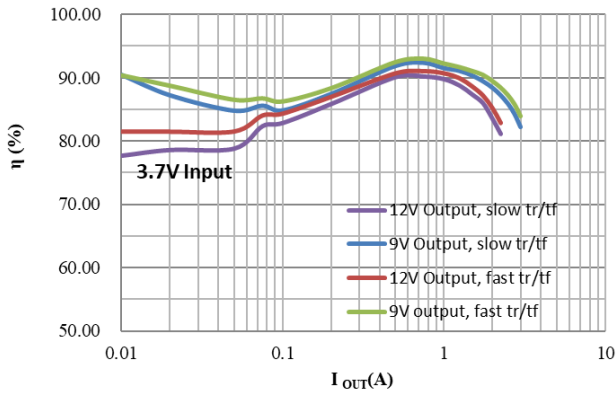

I_{OUT} vs η

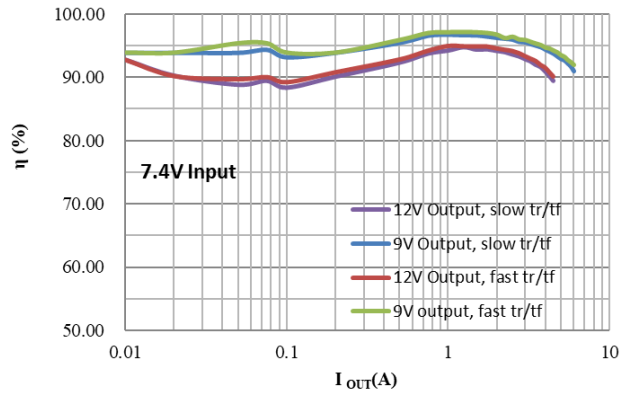

APPLICATION INFORMATION

1 Enable and Startup (EN and SS pin)

The HT71663 has an adjustable soft start function to prevent high inrush current during start-up. The soft start time is normally 5ms.

When the EN pin is pulled into logic low, the HT71663 goes into the shutdown mode and stops switching. Only when EN pin is pulled into logic high, the HT71663 works.

HT71663 具有软起动功能，防止启动时的高浪涌电流。软启动时间一般约 5ms

EN 为芯片使能脚，EN 拉低，芯片进入关断模式，停止开关；EN 拉高，芯片进入工作状态。

2 Switching Frequency

This device features a fix switching frequency. The switching frequency is determined by Vin and Vout. The switching frequency is usually around 450kHz.

HT71663 的开关频率内部固定，与 Vin 和 Vout 相关。其频率一般约为 450kHz。

3 Peak Current Limit

To avoid an accidental large peak current, an internal cycle-by-cycle current limit is adopted. The low-side switch is turned off immediately as soon as the switch current touches the limit. The peak switch current limit is usually around 10A.

芯片采用逐周期电流限制，避免意外的大峰值电流。当开关电流达到设置的限流值，低侧开关管立即断开。峰值开关电流一般约为 10A。

4 Output Voltage Setting (FB pin)

The output voltage is set by an external resistor divider (R_{UP}, R_{DN} in the Typical Application Circuit):

$$V_{OUT} = V_{REF} \times \left(1 + \frac{R_{UP}}{R_{DN}}\right)$$

Where V_{REF} = 1.204V.

Some typical output voltages can be set as the following parameters.

输出电压由外部电阻分压器（R_{UP}，典型应用电路中的 R_{DN}）设置：

Equation 1

其中 V_{REF} = 1.204V。

部分典型电压可参考如下：

Table 1 Typical Output Voltage Settings

| V _{out} (V) | R _{UP} (Ω) | R _{DN} (Ω) |
|----------------------|---------------------|---------------------|
| 5.3 | 510k | 150k |
| 7.4 | 510k | 100k |
| 9.4 | 510k | 75k |
| 12.2 | 510k | 56k |

5 Inductor Selection (SW pin)

The inductor is the most important component in switching power regulator design. Three most important specifications to the performance of the inductor are the inductor value, DC resistance, and saturation current.

To be simplified, the inductor value can be set as 2.2uH which can be used in most cases.

The rated current, especially the saturation current should be larger than the peak current during the whole operation. The peak current can be calculated as follows.

电感是该芯片的关键器件，影响性能的主要是其电感值，直流阻抗，饱和电流。

对于电感值，使用 2.2uH 的电感可以满足大部分应用。

对于额定电流，特别是饱和电流，必须大于所有工作条件下的最大峰值电流，最大峰值电流计算如下：

$$I_{Lpeak} = I_{DC} + \frac{I_{PP}}{2} \quad \text{Equation 2}$$

$$I_{DC} = \frac{V_{OUT} \times I_{OUT}}{V_{IN} \times \eta} \quad \text{Equation 3}$$

$$I_{PP} = \frac{1}{L \times \left(\frac{1}{V_{OUT} - V_{IN}} + \frac{1}{V_{IN}} \right) \times f_{SW}} \quad \text{Equation 4}$$

Boost converter efficiency is affected significantly by the inductor's DC resistance (DCR), equivalent series resistance (ESR) at the switching frequency, and the core loss. An inductor with lower DCR and ESR would increase the efficiency significantly.

The inductor should be placed as close as possible to the SW pin. For a lower EMI radiation, connecting a resistor and a capacitor in series to the ground would be helpful. 1ohm resistor and 3.3nF capacitor would be recommended in most cases.

6 Input Capacitor Selection (VIN, VCC pin)

For good input voltage filtering and small voltage ripple, we recommend low-ESR capacitors of 1uF//10uF//10uF//220uF (“//” represents paralleled) be placed as close as possible to the inductor.

The VIN pin is the power supply for the HT71663, a 1uF paralleled with 10uF ceramic capacitor should be placed as close as possible to the VIN pin. A resistor of 100R is recommended between input power supply and VIN pin so that the power supply of HT71663 would be more stable. An extensive power supply such as the logic power supply connecting to VIN would be another choice.

The VCC pin is the output of internal LDO. A ceramic capacitor of 2.2uF is required at the VCC pin to get a stable operation of LDO.

7 Output Capacitor Selection (VOUT pin)

To be simplified, we recommend low-ESR capacitors of 1uF//10uF//10uF//470uF (“//” represents paralleled) be placed as close as possible to VOUT pin for small output voltage ripple.

In detail, for the require output voltage ripple, use the following equations to calculate the minimum required effective capacitance C_{OUT}

$$V_{ripple_dis} = \frac{(V_{OUT} - V_{INMIN}) \times I_{OUT}}{V_{OUT} \times f_{SW} \times C_{OUT}} \quad \text{Equation 5}$$

$$V_{ripple_ESR} = I_{Lpeak} \times R_{C_ESR} \quad \text{Equation 6}$$

升压效率受电感的直流阻抗、开关频率下的等效 ESR、磁心损耗等影响。选择小的 DCR 和 ESR 可提升效率。

电感应尽可能靠近 SW 引脚放置，并靠近 SW 引脚放置 1ohm 串联 3.3nF 到地。

为了良好的储能和滤波以及减小电压波动，建议电源输入端使用 1uF//10uF//10uF//220uF 组合，放置在靠近电感的大电流路径上。

VIN 脚是 HT71663 的电源供电端，1uF 并联 10uF 对地电容放置在靠近 VIN 脚。输入电源和 VIN 脚之间可以串联 1 个 100R 电阻，已稳定 VIN 电压。VIN 还可以有系统中的逻辑电源供电。

VCC 是内部 LDO 输出，接 2.2uF 电容到地。

简单来说，升压输出到地滤波电容建议使用 1uF//10uF//10uF//470uF 的组合，尽量靠近 Vout 引脚放置。

具体的，可以根据需要的输出电压纹波，得到需要的输出电容值：

Where

- V_{ripple_dis} is output voltage ripple caused by charging and discharging of the output capacitor.
- V_{ripple_ESR} is output voltage ripple caused by ESR of the output capacitor.
- V_{IN_MIN} is the minimum input voltage of boost converter.
- V_{OUT} is the output voltage.
- I_{OUT} is the output current.
- I_{Lpeak} is the peak current of the inductor.
- f_{sw} is the converter switching frequency.
- R_{C_ESR} is the ESR of the output capacitors.

其中:

- V_{ripple_dis} 是对电容充放电引起的输出电压纹波.
- V_{ripple_ESR} 是输出电容ESR引起的输出电压纹波.
- V_{IN_MIN} 是最小输入电压.
- V_{OUT} 是输出电压.
- I_{OUT} 是输出电流.
- I_{Lpeak} 是电感峰值电流.
- f_{sw} 是开关频率.
- R_{C_ESR} 是输出电容 ESR.

8 Loop Stability (COMP pin)

The HT71663 requires external compensation, which allows the loop response to be optimized for each application. The COMP pin is the output of the internal error amplifier. An external compensation network comprised of resistor R_C , ceramic capacitors C_C and C_P is connected to the COMP pin.

To be simplified, R_C is 56k Ω , C_C is 3.3nF, and C_P is 47pF. But notice that this setting can only be adopted in most cases. In detail, the compensation network parameters can be calculated as follows.

(1) Set the cross over frequency, f_c

The first step is to set the loop crossover frequency, f_c . The higher crossover frequency, the faster the loop response is. It is generally accepted that the loop gain cross over no higher than the lower of either 1/10 of the switching frequency, f_{sw} , or 1/5 of the RHPZ frequency, f_{RHPZ} . It's proper to use a fixed parameter of 10kHz for f_c .

HT71663 需要外部补偿, 在 COMP 引脚外接 R_C , C_C , C_P 。简单来说, $R_C=56k\Omega$, $C_C=3.3nF$, $C_P=47pF$ 可以满足大部分应用。以下是补偿网络的计算过程:

(1) 设置交叉频率 f_c

f_c 越大, 响应越快。一般其设置为开关频率的 1/10 或 1/5 的 f_{RHPZ} , 或直接为 10kHz.

$$f_{RHPZ} = \frac{R_O \times (1-D)^2}{2\pi \times L}$$

Equation 7

(2) Set the compensation resistor, R_C .

(2) 设置补偿网络 R_C

$$R_C = \frac{2\pi \times V_{OUT} \times R_{sense} \times f_c \times C_O}{(1-D) \times V_{REF} \times G_{EA}}$$

Equation 8

(3) Set the compensation resistor, C_C .

(3) 设置补偿网络 C_C

$$C_C = \frac{R_O \times C_O}{2 \times R_C}$$

Equation 9

(4) Set the compensation resistor, C_P .

(4) 设置补偿网络 C_P

$$C_P = \frac{R_{ESR} \times C_O}{R_C}$$

Equation 10

If the C_P is less than 10pF, it can be left open.

- R_O is the output load resistance.
- D is the switching duty cycle. $1 - D = V_{IN} / V_{OUT}$
- R_{sense} is the equivalent internal current sense resistor, which is 0.091 Ω .
- C_O is output capacitor.
- V_{REF} is the reference voltage at the FB pin, which is 1.204V.
- G_{EA} is the amplifier's transconductance, which is 204uA/V.
- R_{ESR} is the equivalent series resistance of the output capacitor.

9 Selecting the Bootstrap Capacitor (BOOT pin)

The bootstrap capacitor (C_{BST}) between the BOOT and SW pin supplies the gate current to charge the high-side FET device during each cycle's turn-on and supplies charge for the bootstrap capacitor. The recommended value of the bootstrap capacitor is 0.1 μ F to 1 μ F. C_{BST} should be a good quality, low ESR, ceramic capacitor located at the pins of the device to minimize potentially damaging voltage transients caused by trace inductance. A value of 0.1 μ F can be used in most cases.

10 Protection Function

10.1 Under-voltage Lockout (UVLO)

The UVLO circuit prevents the device from malfunctioning at low input voltage and the battery from excessive discharge. The HT71663 has both VIN UVLO function and VCC UVLO function. It disables the device from switching when the falling voltage at the VIN pin trips the UVLO threshold V_{IN_UVLO} , which is typically 2.3V. The device starts operating when the rising voltage at the VIN pin is 200mV above the V_{IN_UVLO} . It also disables the device when the falling voltage at the VCC pin trips the UVLO threshold V_{CC_UVLO} , which is typically 2.1V.

10.2 Over-voltage Protection

If the output voltage at the VOUT pin is detected above 14.4 V (typical value), the HT71663 stops switching immediately until the voltage at the VOUT pin drops the hysteresis value lower than the output overvoltage protection threshold. This function prevents overvoltage on the output and secures the circuits connected to the output from excessive overvoltage.

10.3 Thermal Shutdown

A thermal shutdown is implemented to prevent damages due to excessive heat and power dissipation. Typically, the thermal shutdown happens at a junction temperature of 150°C. When the thermal shutdown is triggered, the device stops switching until the junction temperature falls below typically 130°C, then the device starts switching again.

如果 C_p 小于 10pF, 可以悬空。

其中 R_o 是输出负载;

D 是占空比, $1 - D = V_{IN} / V_{OUT}$

R_{sense} 是内部等效电流感应电阻, 0.091 Ω

C_o 是输出电容

V_{REF} 是 FB 电压, 1.204V

G_{EA} 是跨导, 204uA/V

R_{ESR} 是输出电容的等效串联电阻。

BOOT 和 SW 之间需放置一个 C_{BST} 电容, 用于高端管开启时的栅极驱动。一般使用 0.1uF~1uF, 大部分情况下可使用 0.1uF 电容。

HT71663 具有 VIN 和 VCC 欠压保护。当 VIN 小于 V_{IN_UVLO} (典型 2.3V) 时, 器件停止开关, 直至 VIN 大于 V_{IN_UVLO} (典型 2.5V), 器件重新工作。当 VCC 小于 V_{CC_UVLO} (典型 2.1V) 时, 器件同样停止工作。

当 VOUT 电压高于 14.4V (典型值), HT71663 停止工作, 直到 VOUT 低于 14V (典型值)。

芯片具有过温关断保护功能。当结温大于 160°C (典型值), 芯片关断; 当结温低于 140°C (典型值), 芯片恢复工作。

PACKAGE OUTLINE

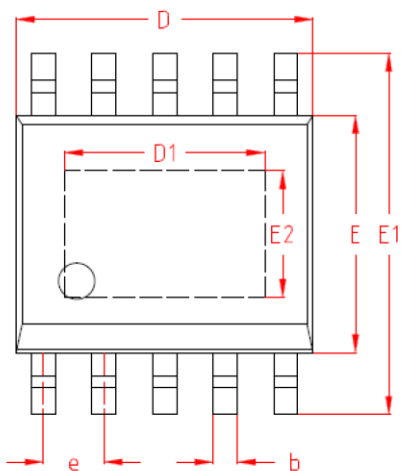
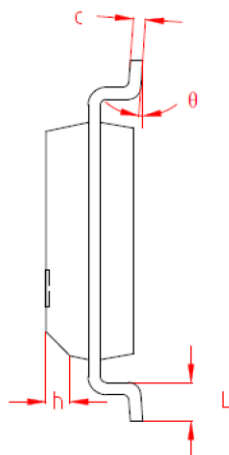
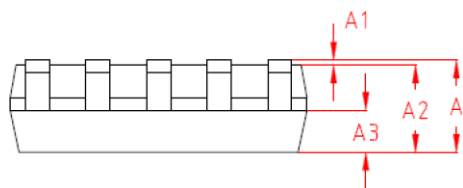
 TOP VIEW
 正视图

 SIDE VIEW
 侧视图

 SIDE VIEW
 侧视图

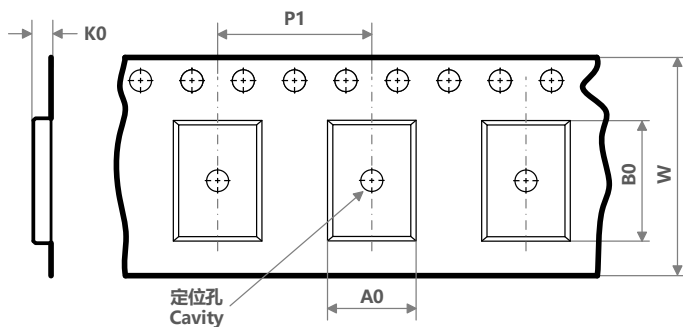
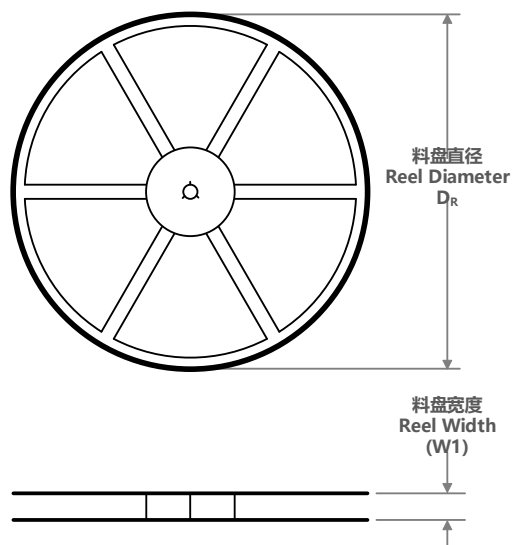
| 机械尺寸/mm Dimensions | | | |
|-----------------------|------------|----------------|------------|
| 字符 SYMBOL | 最小值 MIN | 典型值 NOMINAL | 最大值 MAX |
| A | 1.50 | 1.60 | 1.70 |
| A1 | 0.04 | - | 0.12 |
| A2 | 1.35 | 1.45 | 1.55 |
| A3 | 0.65 | 0.70 | 0.75 |
| b | 0.35 | - | 0.50 |
| c | 0.19 | - | 0.25 |
| D | 4.80 | 4.90 | 5.00 |
| D1 | 3.20 | 3.30 | 3.40 |
| E | 3.80 | 3.90 | 4.00 |
| E1 | 5.80 | 6.00 | 6.20 |
| E2 | 2.00 | 2.10 | 2.20 |
| e | 1.00 BSC | | |
| h | 0.30 | - | 0.50 |
| L | 0.50 | - | 0.80 |
| θ | 0° | - | 8° |

TAPE AND REEL INFORMATION



| | |
|-----------|---|
| A0 | Dimension designed to accommodate the component width; 料槽宽度 |
| B0 | Dimension designed to accommodate the component length; 料槽长度 |
| K0 | Dimension designed to accommodate the component thickness; 料槽厚度 |
| W | Overall width of the carrier tape; 载带整体宽度 |
| P1 | Pitch between successive cavity centers; 相邻槽中心间距 |

编带 PIN1 方位象限分配
Quadrant Assignments for Pin1 Orientation in Tape

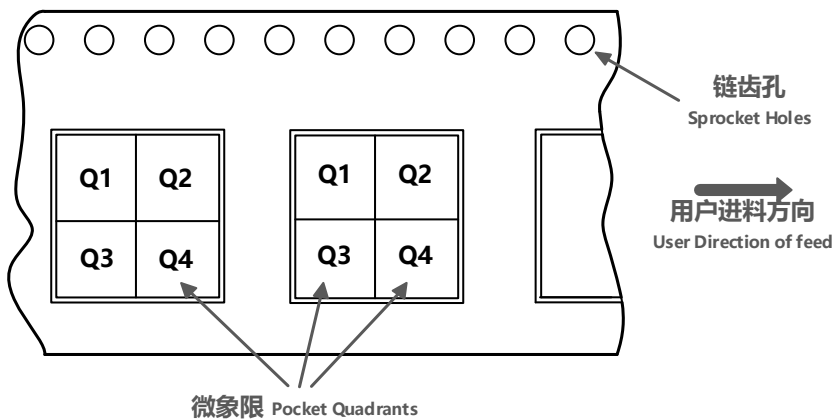

| 器件料号 Part No. | 封装类型 Package Type | 封装标识 Package Code | 引脚数 Pins | SPQ | 料盘直径 D_R (mm) | 料盘宽度 W_1 (mm) | A_0 (mm) | B_0 (mm) | K_0 (mm) | P_1 (mm) | W (mm) | Pin1 象限 Quadrant |
|------------------|----------------------|----------------------|-------------|------|--------------------|--------------------|------------|------------|------------|------------|----------|---------------------|
| HT71663SPER | ESOP | SPE | 10 | 2500 | 330 | 12.5 | 6.55 | 5.25 | 2 | 8 | 12 | Q1 |

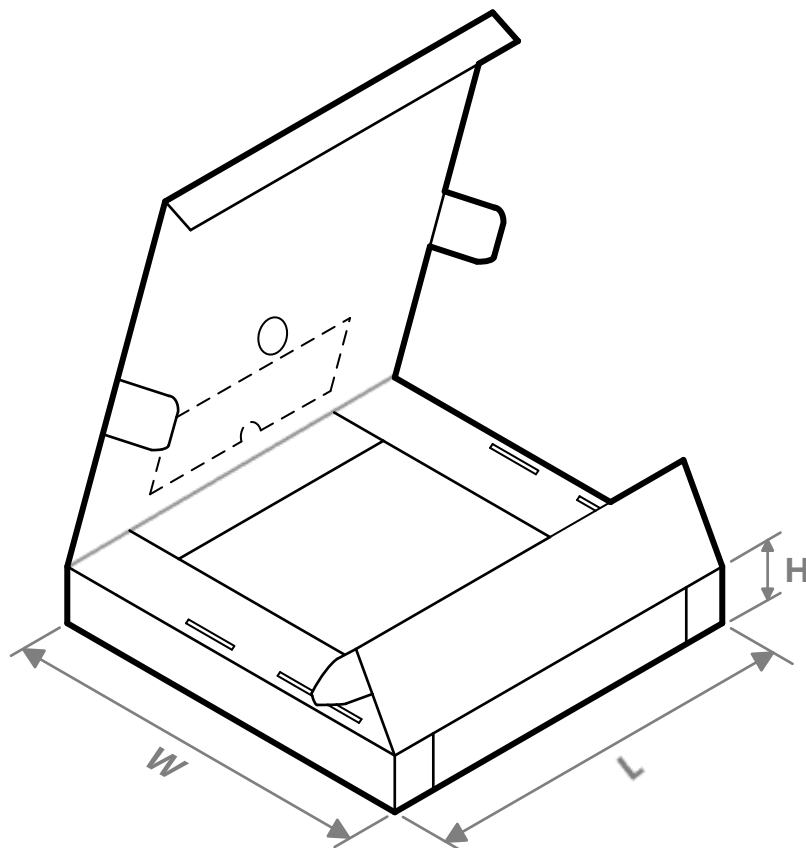
TAPE AND REEL BOX INFORMATION

| 器件料号 Part No. | 封装类型 Package Type | 封装标识 Package Code | 引脚数 Pins | SPQ | 长度 Length (mm) | 宽度 Width (mm) | 高度 Height (mm) |
|------------------|----------------------|----------------------|-------------|------|----------------------|------------------|-------------------|
| HT71663SPER | ESOP | SPE | 10 | 5000 | 380 | 340 | 60 |

IMPORTANT NOTICE**注意**

Heroic Electronic Technology (Jiaxing) Co., Ltd (HT) reserves the right to make corrections, modifications, enhancements, improvements, and other changes to its products and services at any time and to discontinue any products or services. Customers should obtain the latest relevant information before placing orders and should verify that such information is current and complete.

禾润电子科技（嘉兴）股份有限公司（以下简称HT）保留对产品、服务、文档的任何修改、更正、提高、改善和其他改变，或停止提供任何产品和服务的权利。客户在下单和生产前应确保所得到的信息是最新、最完整的。

HT assumes no liability for applications assistance or customer product design. Customers are responsible for their products and applications using HT components.

HT对相关应用的说明和协助以及客户产品的板级设计不承担任何责任。

HT products are not authorized for use in safety-critical applications (such as life support devices or systems) where a failure of the HT product would reasonably be expected to affect the safety or effectiveness of that devices or systems.

HT的产品并未授权用于诸如生命维持设备等安全性极高的应用中。

The information included herein is believed to be accurate and reliable. However, HT assumes no responsibility for its use; nor for any infringement of patents or other rights of third parties which may result from its use.

本文中的相关信息是精确和可靠的，但HT并不对其负责，也不对任何可能的专利和第三方权利的侵害负责。

Following are URLs and contacts where you can obtain information or supports on any HT products and application solutions:

下面是可以联系到我公司的相关链接和联系方式：

禾润电子科技（嘉兴）股份有限公司
Heroic Electronic Technology (Jiaxing) Co., Ltd.

地址：浙江省嘉兴市凌公塘路3339号JRC大厦A座三层

Add: A 3rd floor, JRC Building, No. 3339, LingGongTang Road, Jiaxing, Zhejiang Province

Sales: 0573-82585539, sales@heroic.com.cn

Support: 0573-82586151, support@heroic.com.cn

Fax: 0573-82585078

Website: www.heroic.com.cn; wap.heroic.com.cn

Wechat MP: HEROIC_JX

请及时关注禾润官方微信公众号，随时获取最新产品信息和技术资料！

