

Low-Voltage I/O TOUCH SCREEN CONTROLLER

■ FEATURES

- 2.2V TO 5.25V OPERATION
- 1.5V TO 5.25V DIGITAL I/O
- INTERNAL 2.5V REFERENCE
- DIRECT BATTERY MEASUREMENT (0V TO 6V)
- ON-CHIP TEMPERATURE MEASUREMENT
- TOUCH-PRESSURE MEASUREMENT
- QSPI AND SPI 3-WIRE INTERFACE
- AUTO POWER-DOWN
- AVAILABLE IN QFN-16 PACKAGE

■ APPLICATIONS

- PERSONAL DIGITAL ASSISTANTS
- PORTABLE INSTRUMENTS
- POINT-OF-SALE TERMINALS · PAGERS
- TOUCH SCREEN MONITORS
- CELLULAR PHONES

■ DESCRIPTION

The HT2046 is a 4-wire touch screen controller which supports a low-voltage I/O interface from 1.5V to 5.25V. The HT2046 also has an on-chip 2.5V reference that can be used for the auxiliary input, battery monitor, and temperature measurement modes. The reference can also be powered down when not used to conserve power. The internal reference operates down to 2.7V supply voltage, while monitoring the battery voltage from 0V to 6V.

The low power consumption of < 0.75mW typ at 2.7V (reference off), high-speed (up to 125kHz sample rate), and on-chip drivers make the HT2046 an ideal choice for battery-operated systems such as personal digital assistants (PDAs) with resistive touch screens, pagers, cellular phones, and other portable equipment. The HT2046 is available in QFN-16 package and is specified over the -40°C to +85°C temperature range.

■ BLOCK DIAGRAM

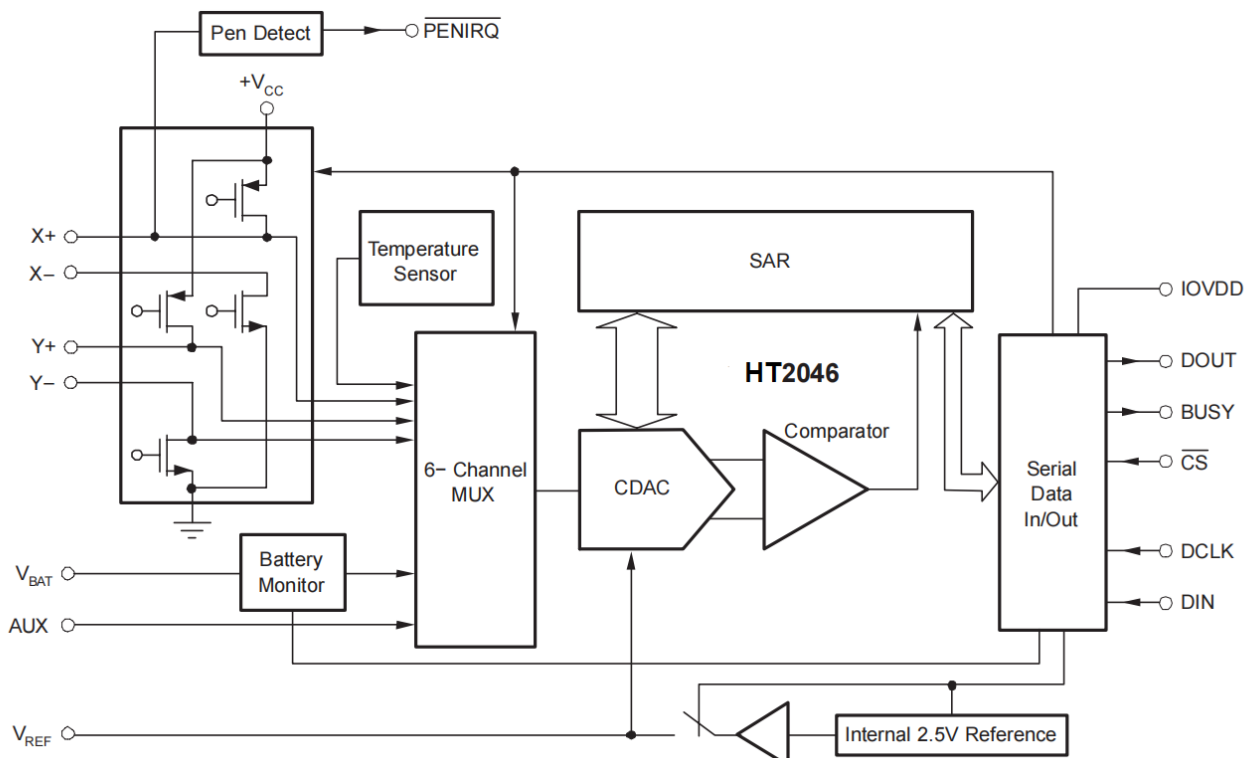

Contents

■ FEATURES	1
■ APPLICATIONS.....	1
■ DESCRIPTION.....	1
■ BLOCK DIAGRAM	1
■ TERMINAL CONFIGURATION	3
■ TERMINAL FUNCTION.....	3
■ ORDERING INFORMATION	4
■ ELECTRICAL CHARACTERISTICS.....	5
● Absolute Maximum Ratings	5
● ELECTRICAL CHARACTERISTICS	5
■ APPLICATION INFORMATION.....	8
1. <i>THEORY OF OPERATION</i>	8
2. <i>ANALOG INPUT</i>	8
3. <i>INTERNAL REFERENCE</i>	10
4. <i>REFERENCE INPUT</i>	10
5. <i>TOUCH SCREEN SETTLING</i>	12
6. <i>TEMPERATURE MEASUREMENT</i>	12
7. <i>BATTERY MEASUREMENT</i>	13
8. <i>BATTERY MEASUREMENT</i>	13
9. <i>DIGITAL INTERFACE</i>	14
10. <i>Control Byte</i>	15
11. <i>\PENIRQ OUTPUT</i>	17
12. <i>Clocks-per-Conversion</i>	18
13. <i>Digital Timing</i>	18
14. <i>Digital Timing</i>	19
15. <i>8-Bit Conversion</i>	19
16. <i>POWER DISSIPATION</i>	20
17. <i>LAYOUT</i>	21
■ PACKAGE OUTLINE.....	23

■ TERMINAL CONFIGURATION

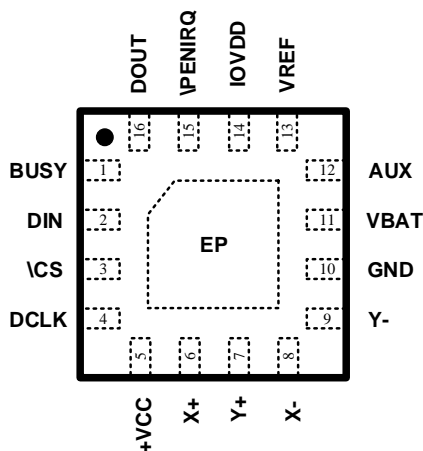

QFN16 Top View

■ TERMINAL FUNCTION

Terminal No.	NAME	Description
1	BUSY	Busy Output. This output is high impedance when \CS is high.
2	DIN	Serial Data Input. If \CS is low, data are latched on the rising edge of DCLK.
3	\CS	Chip Select Input. Controls conversion timing and enables the serial input/output register. \CS high = power-down mode (ADC only).
4	DCLK	External Clock Input. This clock runs the SAR conversion process and synchronizes serial data I/O.
5	+VCC	Power Supply
6	X+	X+ Position Input
7	Y+	Y+ Position Input
8	X-	X- Position Input
9	Y-	Y- Position Input
10	GND	Ground
11	VBAT	Battery Monitor Input
12	AUX	Auxiliary Input to ADC
13	VREF	Voltage Reference Input/Output
14	IOVDD	Digital I/O Power Supply
15	\PENIRQ	Pen Interrupt
16	DOUT	Serial Data Output. Data are shifted on the falling edge of DCLK. This output is high impedance when \CS is high.
EP		The thermal pad is internally connected to the substrate. This pad can be connected to the analog ground or left floating. Keep the thermal pad separate from the digital ground, if possible.

■ ORDERING INFORMATION

To be continued.

ELECTRICAL CHARACTERISTICS¹

Absolute Maximum Ratings²

PARAMETER	SYMBOL	MIN	MAX	UNIT
+VCC and IOVDD to GND		-0.3	6	V
Analog Inputs to GND		-0.3	+VCC + 0.3V	V
Digital Inputs to GND		-0.3	IOVDD + 0.3V	V
Power Dissipation			250mW	V
Junction temperature range	T _J		150	°C
Operating Temperature Range		-40	85	°C
Storage temperature range	T _{STG}	-65	150	°C
Lead Temperature (soldering, 10s)			300	°C

ELECTRICAL CHARACTERISTICS

At T_A = -40°C to +85°C, +VCC = +2.7V, VREF = 2.5V internal voltage, f_{SAMPLE} = 125kHz, f_{CLK} = 16 • f_{SAMPLE} = 2MHz, 12-bit mode, digital inputs = GND or IOVDD, and +VCC must be ≥ IOVDD, unless otherwise noted.

PARAMETER	CONDITION	MIN	TYP	MAX	UNIT
Analog Input					
Full-Scale Input Span	Positive Input–Negative Input	0		V _{REF}	V
Absolute Input Range	Positive Input	-0.2		+VCC + 0.2	V
	Negative Input	-0.2		+0.2	V
Capacitance			25		pF
Leakage Current			0.1		uA
SYSTEM PERFORMANCE					
Resolution			12		Bits
No Missing Codes		11			Bits
Integral Linearity Error				±2	LSB ³
Offset Error				±6	LSB
Gain Error	External VREF			±4	LSB
Noise	Including Internal VREF		70		μVrms
Power-Supply Rejection			70		dB
SAMPLING DYNAMICS					
Conversion Time				12	CLK Cycles
Acquisition Time		3			CLK Cycles
Throughput Rate				125	kHz
Multiplexer Settling Time			500		ns
Aperture Delay			30		ns
Aperture Jitter			100		ps
Channel-to-Channel Isolation	VIN = 2.5VPP at 50kHz		100		dB

¹ Depending on parts and PCB layout, characteristics may be changed.

² Stresses beyond those listed under absolute maximum ratings may cause permanent damage to the device. These are stress ratings only, and functional operation of the device at these or any other conditions beyond those indicated under recommended operating conditions is not implied. Exposure to absolute–maximum–rated conditions for extended periods may affect device reliability

³ LSB means Least Significant Bit. With VREF = +2.5V, one LSB is 610μV

PARAMETER	CONDITION	MIN	TYP	MAX	UNIT
SWITCH DRIVERS					
On-Resistance	Y+, X+		5		Ω
	Y-, X-		6		Ω
Drive Current ⁴	Duration 100ms			50	mA
REFERENCE OUTPUT					
Internal Reference Voltage			2.5		V
Internal Reference Drift			15		ppm/°C
Quiescent Current			500		μA
REFERENCE INPUT					
Range	SER/DFR = 0, PD1 = 0	1.0		=VCC	V
Input Impedance	Internal Reference Off		1		GΩ
	Internal Reference On		250		Ω
BATTERY MONITOR					
Input Voltage Range		0.5		6.0	V
Input Impedance	Sampling Battery		10		kΩ
	Battery Monitor Off		1		GΩ
Accuracy	VBAT = 0.5V to 5.5V, External VREF = 2.5V	-2		+2	%
	VBAT = 0.5V to 5.5V, Internal Reference	-3		+3	%
TEMPERATURE MEASUREMENT					
Temperature Range		-40		+85	°C
Resolution	Differential Method ⁵		1.6		°C
	TEMP0 ⁶		0.3		°C
Accuracy	Differential Method		±2		°C
	TEMP0		±3		°C
DIGITAL INPUT/OUTPUT					
Logic Family			CMOS		
Capacitance	All Digital Control Input Pins		5	15	pF
V _{IH}	I _{IH} ≤ +5μA	IOVDD • 0.7		IOVDD + 0.3	V
V _{IL}	I _{IL} ≤ +5μA	-0.3		0.3 • IOVDD	V
V _{OH}	I _{OH} = -250μA	IOVDD • 0.8			V
V _{OL}	I _{OL} = 250μA			0.4	V
Data Format			Straight Binary		
POWER-SUPPLY REQUIREMENTS					
+VCC	Specified Performance	2.7		3.6	V
	Operating Range	2.2		5.25	V
IOVDD ⁷		1.5		+VCC	V
Quiescent Current ⁸	Internal Reference Off		280	650	uA
	Internal Reference On		780		uA
	f _{SAMPLE} = 12.5kHz		220		uA

⁴ Assured by design, but not tested. Exceeding 50mA source current may result in device degradation.

⁵ Difference between TEMP0 and TEMP1 measurement, no calibration necessary

⁶ Temperature drift is -2.1mV/°C.

⁷ IOVDD must be ≤ (+VCC).

⁸ Combined supply current from +VCC and IOVDD. Typical values obtained from conversions on AUX input with PD0 = 0.

	Power-Down Mode with VCS = DCLK = DIN = IOVDD		3		uA
	+VCC = +2.7V		1.8		mW
TEMPERATURE RANGE					
Specified Performance		-40		+85	°C

APPLICATION INFORMATION

1. THEORY OF OPERATION

The HT2046 is a classic successive approximation register (SAR) analog-to-digital converter (ADC). The architecture is based on capacitive redistribution, which inherently includes a sample-and-hold function. The converter is fabricated on a CMOS process. The basic operation of the HT2046 is shown in Figure 1. The device features an internal 2.5V reference and uses an external clock. Operation is maintained from a single supply of 2.7V to 5.25V. The internal reference can be overdriven with an external, low-impedance source between 1V and +VCC. The value of the reference voltage directly sets the input range of the converter.

The analog input (X-, Y-, and Z-Position coordinates, auxiliary input, battery voltage, and chip temperature) to the converter is provided via a multiplexer. A unique configuration of low on-resistance touch panel driver switches allows an unselected ADC input channel to provide power and the accompanying pin to provide ground for an external device, such as a touch screen. By maintaining a differential input to the converter and a differential reference architecture, it is possible to negate the error from each touch panel driver switch on-resistance (if this is a source of error for the particular measurement).

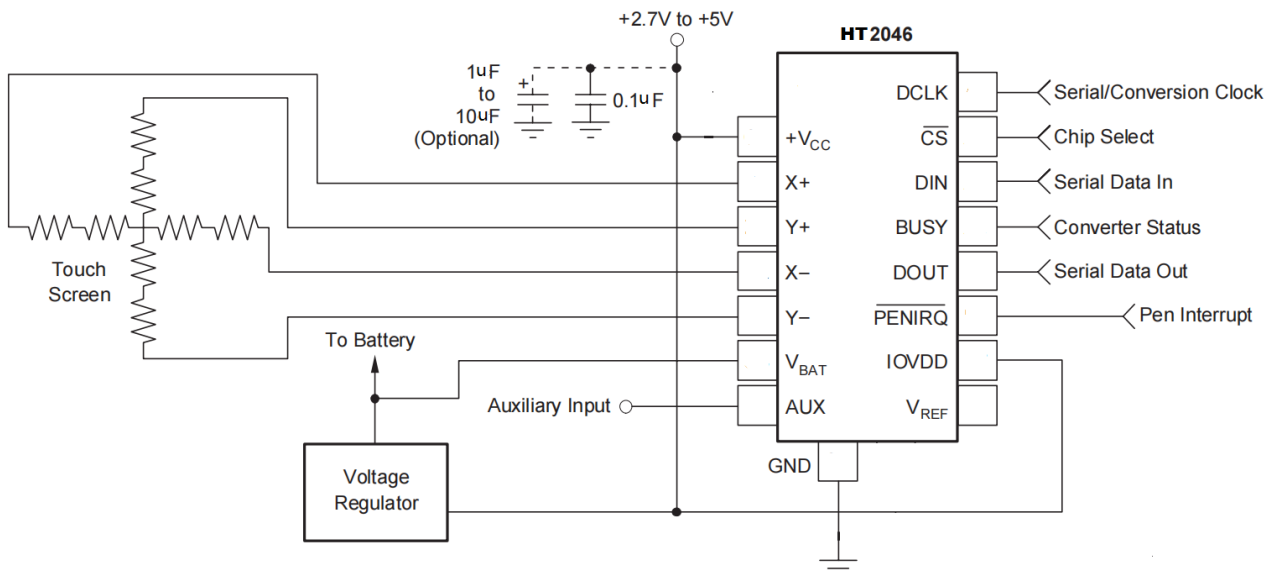

Figure 1 Basic Operation of the HT2046

2. ANALOG INPUT

Figure 2 shows a block diagram of the input multiplexer on the HT2046, the differential input of the ADC, and the differential reference of the converter. Table 1 and Table 2 show the relationship between the A2, A1, A0, and SER/DFR control bits and the configuration of the HT2046. The control bits are provided serially via the DIN pin—see the Digital Interface section of this data sheet for more details.

When the converter enters the hold mode, the voltage difference between the +IN and –IN inputs (shown in Figure 2) is captured on the internal capacitor array. The input current into the analog inputs depends on the conversion rate of the device. During the sample period, the source must charge the internal sampling capacitor (typically 25pF). After the capacitor is fully charged, there is no further input current. The rate of charge transfer from the analog source to the converter is a function of conversion rate.

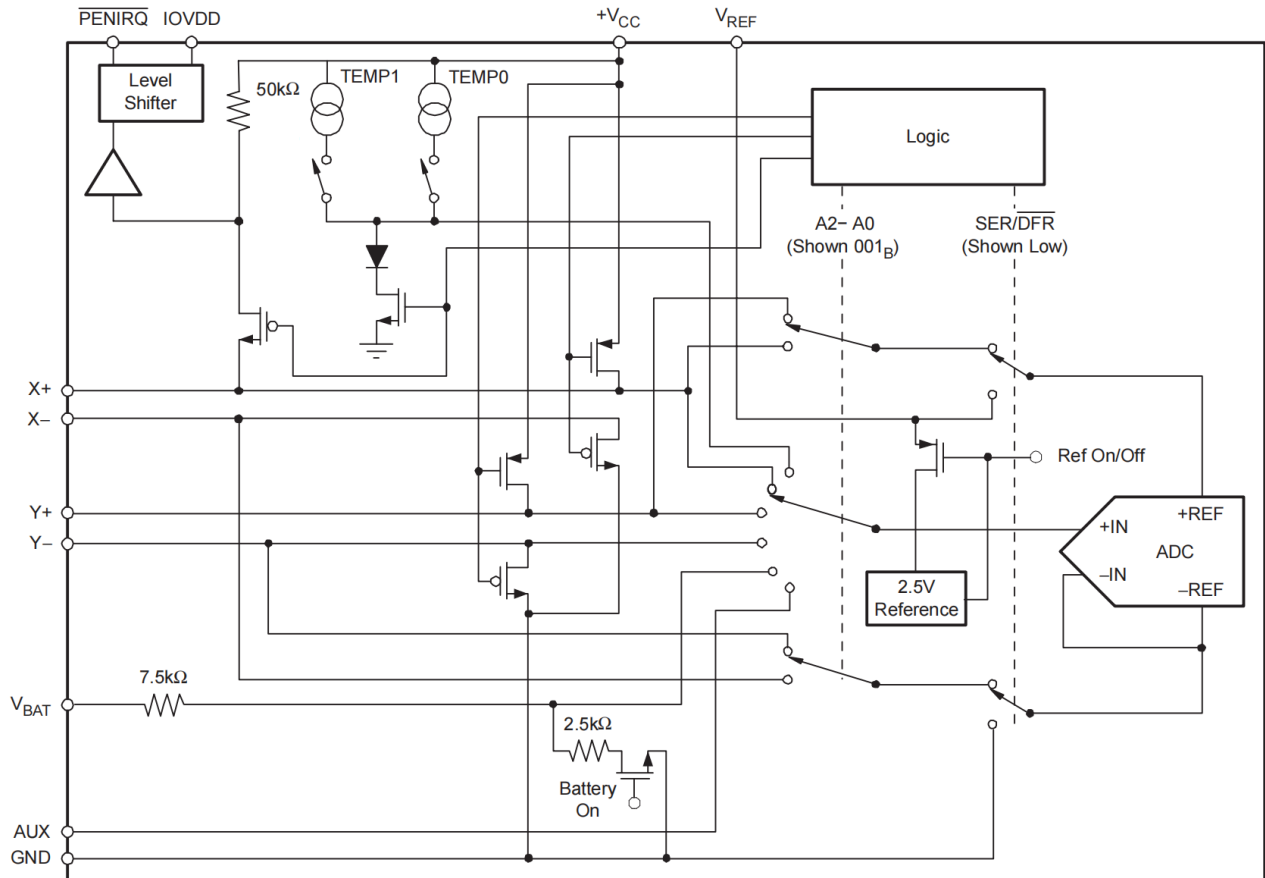

Figure 2 Simplified Diagram of Analog Input

Table 1 Input Configuration (DIN), Single-Ended Reference Mode (SER/ADFR high)

A2	A1	A0	VBAT	AUX _{IN}	TEMP	Y-	X+	Y+	Y- Position	X- Position	Z1- Position	Z2- Position	X- Drivers	Y- Drivers
0	0	0			+IN(TEMP0)								Off	Off
0	0	1					+IN		Measure				Off	Off
0	1	0	+IN										Off	Off
0	1	1					+IN				Measure		X-, On	Y+, On
1	0	0				+IN						Measure	X-, On	Y+, On
1	0	1						+IN		Measure				Off
1	1	0		+IN										Off
1	1	1			+IN(TEMP1)									Off

Table 2 Input Configuration (DIN), Differential Reference Mode (SER/DFR low)

A2	A1	A0	+REF	-REF	Y-	X+	Y+	Y-Position	X-Position	Z1-Position	Z2-Position	Drivers
0	0	1	Y+	Y-		+IN		Measure				Y+, Y-
0	1	1	Y+	Y-		+IN				Measure		Y+, X-
1	0	0	Y+	X-	+IN						Measure	Y+, X-
1	0	1	X+	X-			+IN		Measure			X+, X-

3. INTERNAL REFERENCE

The HT2046 has an internal 2.5V voltage reference that can be turned on or off with the control bit, PD1 (see Table 5 and Figure 3). Typically, the internal reference voltage is only used in the single-ended mode for battery monitoring, temperature measurement, and for using the auxiliary input. Optimal touch screen performance is achieved when using the differential mode. The internal reference voltage of the HT2046 must be commanded to be off to maintain compatibility with the ADS7843. Therefore, after power-up, a write of PD1 = 0 is required to ensure the reference is off (see the Typical Characteristics for power-up time of the reference from power-down).

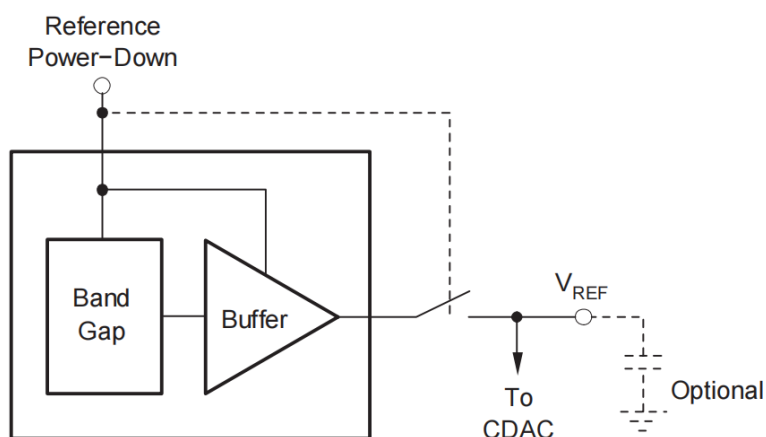

Figure 3 Simplified Diagram of the Internal Reference

4. REFERENCE INPUT

The voltage difference between +REF and -REF (see Figure 2) sets the analog input range. The HT2046 operates with a reference in the range of 1V to +VCC. There are several critical items concerning the reference input and its wide voltage range. As the reference voltage is reduced, the analog voltage weight of each digital output code is also reduced. This is often referred to as the LSB (least significant bit) size and is equal to the reference voltage divided by 4096 in 12-bit mode. Any offset or gain error inherent in the ADC appears to increase, in terms of LSB size, as the reference voltage is reduced. For example, if the offset of a given converter is 2LSBs with a 2.5V reference, it is typically 5LSBs with a 1V reference. In each case, the actual offset of the device is the same, 1.22mV. With a lower reference voltage, more care must be taken to provide a clean layout including adequate bypassing, a clean (low-noise, low-ripple) power supply, a low-noise reference (if an external reference is used), and a low-noise input signal.

The voltage into the VREF input directly drives the capacitor digital-to-analog converter (CDAC) portion of the HT2046. Therefore, the input current is very low (typically < 13µA).

There is also a critical item regarding the reference when making measurements while the switch drivers are ON. For this discussion, it is useful to consider the basic operation of the HT2046 (see Figure 1). This particular application shows the device being used to digitize a resistive touch screen. A measurement of the current Y-Position of the pointing device is made by connecting the X+ input to the ADC, turning on the Y+

and Y- drivers, and digitizing the voltage on X+ (Figure 4 shows a block diagram). For this measurement, the resistance in the X+ lead does not affect the conversion (it does affect the settling time, but the resistance is usually small enough that this is not a concern). However, since the resistance between Y+ and Y- is fairly low, the on-resistance of the Y drivers does make a small difference. Under the situation outlined so far, it is not possible to achieve a 0V input or a full-scale input regardless of where the pointing device is on the touch screen because some voltage is lost across the internal switches. In addition, the internal switch resistance is unlikely to track the resistance of the touch screen, providing an additional source of error.

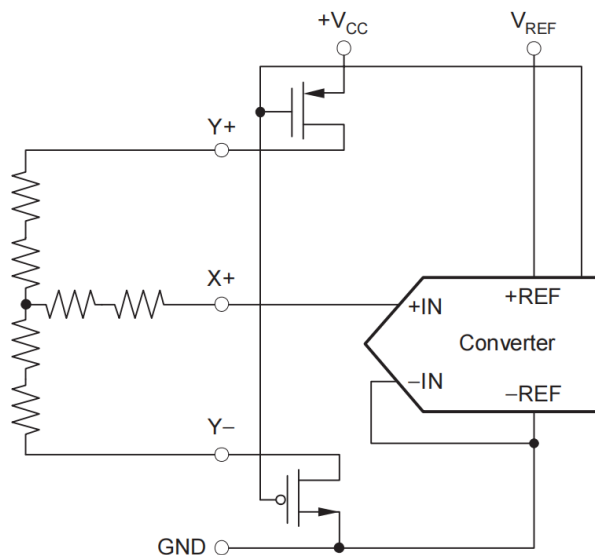

Figure 4 Simplified Diagram of Single-Ended Reference (SER/DFR high, Y switches enabled, X+ is analog input)

This situation can be remedied as shown in Figure 5. By setting the SER/DFR bit low, the +REF and -REF inputs are connected directly to Y+ and Y-, respectively, which makes the analog-to-digital conversion ratiometric. The result of the conversion is always a percentage of the external resistance, regardless of how it changes in relation to the on-resistance of the internal switches. Note that there is an important consideration regarding power dissipation when using the ratiometric mode of operation (see the Power Dissipation section for more details).

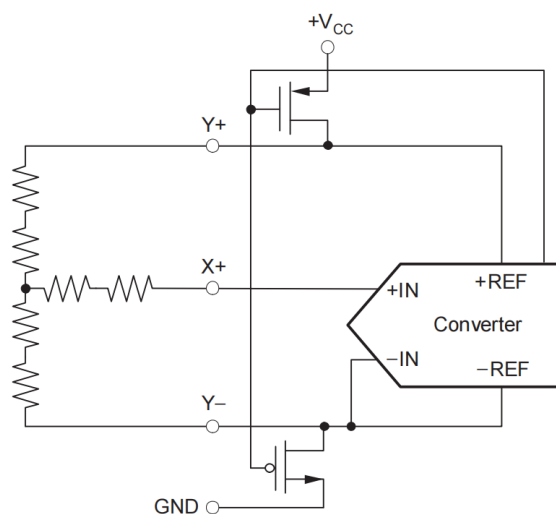

Figure 5 Simplified Diagram of Differential Reference (SER/DFR low, Y switches enabled, X+ is analog input)

As a final note about the differential reference mode, it must be used with +VCC as the source of the +REF voltage and cannot be used with VREF. It is possible to use a high-precision reference on VREF and single-

ended reference mode for measurements that do not need to be ratiometric. In some cases, it is possible to power the converter directly from a precision reference. Most references can provide enough power for the HT2046, but might not be able to supply enough current for the external load (such as a resistive touch screen).

5. TOUCH SCREEN SETTLING

In some applications, external capacitors may be required across the touch screen for filtering noise picked up by the touch screen (e.g., noise generated by the LCD panel or backlight circuitry). These capacitors provide a low-pass filter to reduce the noise, but cause a settling time requirement when the panel is touched that typically shows up as a gain error. There are several methods for minimizing or eliminating this issue. The problem is that the input and/or reference has not settled to the final steady-state value prior to the ADC sampling the input(s) and providing the digital output. Additionally, the reference voltage may still be changing during the measurement cycle. Option 1 is to stop or slow down the HT2046 DCLK for the required touch screen settling time. This allows the input and reference to have stable values for the Acquire period (3 clock cycles of the HT2046; see Figure 9). This works for both the single-ended and the differential modes. Option 2 is to operate the HT2046 in the differential mode only for the touch screen measurements and command the HT2046 to remain on (touch screen drivers ON) and not go into power-down (PD0 = 1). Several conversions are made depending on the settling time required and the HT2046 data rate. Once the required number of conversions have been made, the processor commands the HT2046 to go into its power-down state on the last measurement. This process is required for X-Position, Y-Position, and Z-Position measurements. Option 3 is to operate in the 15 Clock-per-Conversion mode, which overlaps the analog-to-digital conversions and maintains the touch screen drivers on until commanded to stop by the processor (see Figure 13).

6. TEMPERATURE MEASUREMENT

In some applications, such as battery recharging, a measurement of ambient temperature is required. The temperature measurement technique used in the HT2046 relies on the characteristics of a semiconductor junction operating at a fixed current level. The forward diode voltage (V_{BE}) has a well-defined characteristic versus temperature. The ambient temperature can be predicted in applications by knowing the $+25^{\circ}\text{C}$ value of the VBE voltage and then monitoring the delta of that voltage as the temperature changes. The HT2046 offers two modes of operation. The first mode requires calibration at a known temperature, but only requires a single reading to predict the ambient temperature. A diode is used (turned on) during this measurement cycle. The voltage across the diode is connected through the MUX for digitizing the forward bias voltage by the ADC with an address of $A2 = 0$, $A1 = 0$, and $A0 = 0$ (see Table 1 and Figure 6 for details). This voltage is typically 600mV at $+25^{\circ}\text{C}$ with a $20\mu\text{A}$ current through the diode. The absolute value of this diode voltage can vary a few millivolts. However, the TC of this voltage is very consistent at $-2.1\text{mV}/^{\circ}\text{C}$. During the final test of the end product, the diode voltage would be stored at a known room temperature, in memory, for calibration purposes by the user. The result is an equivalent temperature measurement resolution of $0.3^{\circ}\text{C}/\text{LSB}$ (in 12-bit mode)

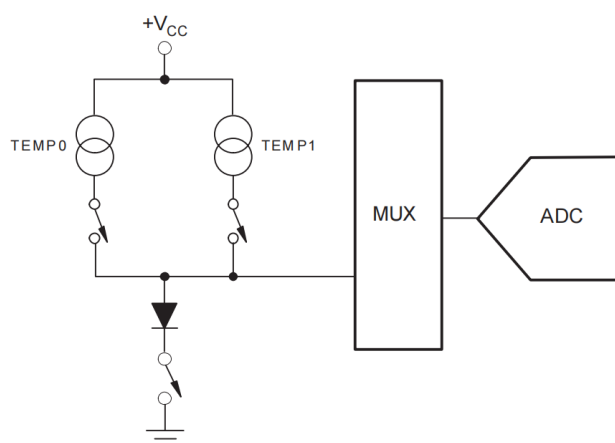

Figure 6 Functional Block Diagram of Temperature Measurement

The second mode does not require a test temperature calibration, but uses a two-measurement method to eliminate the need for absolute temperature calibration and for achieving 2°C accuracy. This mode requires a second conversion with an address of A2 = 1, A1 = 1, and A0 = 1, with a 91 times larger current. The voltage difference between the first and second conversion using 91 times the bias current is represented by Equation (1):

$$\Delta V = \frac{kT}{q} \times \ln(N)$$

where:

N is the current ratio = 91.

k = Boltzmann's constant = 1.3807×10^{-23} J/K (joules/kelvins).

q = the electron charge = 1.6022×10^{-19} C (coulombs).

T = the temperature in kelvins (K).

This method can provide improved absolute temperature measurement, but at a lower resolution of 1.6°C/LSB. The resulting equation that solves for T is:

$$T = \frac{q \times \Delta V}{k \times \ln(N)}$$

where:

$$\Delta V = V_{BE}(\text{TEMP1}) - V_{BE}(\text{TEMP0}) \text{ (in mV)}$$

$$\therefore T = 2.573 \cdot \Delta V \text{ (in K)}$$

$$\text{or } T = 2.573 \cdot \Delta V - 273 \text{ (in } ^\circ\text{C)}$$

NOTE: The bias current for each diode temperature measurement is only on for 3 clock cycles (during the acquisition mode) and, therefore, does not add any noticeable increase in power, especially if the temperature measurement only occurs occasionally.

7. BATTERY MEASUREMENT

An added feature of the HT2046 is the ability to monitor the battery voltage on the other side of the voltage regulator (DC/DC converter), as shown in Figure 7. The battery voltage can vary from 0V to 6V, while maintaining the voltage to the HT2046 at 2.7V, 3.3V, etc. The input voltage (VBAT) is divided down by 4 so that a 5.5V battery voltage is represented as 1.375V to the ADC. This simplifies the multiplexer and control logic. In order to minimize the power consumption, the divider is only on during the sampling period when A2 = 0, A1 = 1, and A0 = 0 (see Table 1 for the relationship between the control bits and configuration of the HT2046).

8. BATTERY MEASUREMENT

Measuring touch pressure can also be done with the HT2046. To determine pen or finger touch, the pressure of the touch needs to be determined. Generally, it is not necessary to have very high performance for this test; therefore, the 8-bit resolution mode is recommended (however, calculations will be shown here in the 12-bit resolution mode). There are several different ways of performing this measurement. The HT2046 supports two methods. The first method requires knowing the X-plate resistance, measurement of the X-Position, and two additional cross panel measurements (Z_1 and Z_2) of the touch screen, as shown in Figure 8. Using Equation (3) calculates the touch resistance:

$$R_{TOUCH} = R_{X-plate} \times \frac{X-Position}{4096} \left(\frac{Z_2}{Z_1} - 1 \right)$$

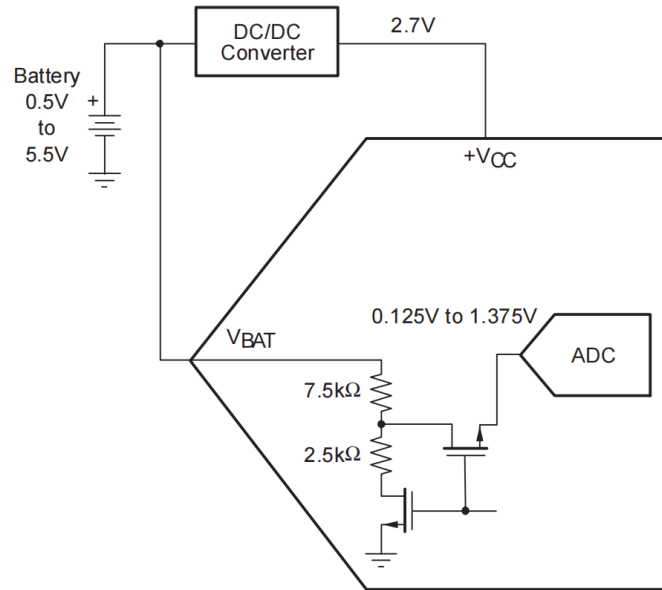

Figure 7 Battery Measurement Functional Block Diagram

The second method requires knowing both the X-plate and Y-plate resistance, measurement of X-Position and Y-Position, and Z_1 . Using Equation (4) also calculates the touch resistance:

$$R_{TOUCH} = \frac{R_{X-plate} \times X - Position}{4096} \left(\frac{4096}{Z_1} - 1 \right) - R_{Y-plate} \left(1 - \frac{Y - Position}{4096} \right)$$

9. DIGITAL INTERFACE

See Figure 9 for the typical operation of the HT2046 digital interface. This diagram assumes that the source of the digital signals is a microcontroller or digital signal processor with a basic serial interface. Each communication between the processor and the converter, such as SPI, SSI, or Microwiresynchronous serial interface, consists of eight clock cycles. One complete conversion can be accomplished with three serial communications for a total of 24 clock cycles on the DCLK input.

The first eight clock cycles are used to provide the control byte via the DIN pin. When the converter has enough information about the following conversion to set the input multiplexer and reference inputs appropriately, the converter enters the acquisition (sample) mode and, if needed, the touch panel drivers are turned on. After three more clock cycles, the control byte is complete and the converter enters the conversion mode. At this point, the input sample-and-hold goes into the hold mode and the touch panel drivers turn off (in single-ended mode). The next 12 clock cycles accomplish the actual analog-to-digital conversion. If the conversion is ratiometric ($SER/DFR = 0$), the drivers are on during the conversion and a 13th clock cycle is needed for the last bit of the conversion result. Three more clock cycles are needed to complete the last byte (DOUT will be low), which are ignored by the converter.

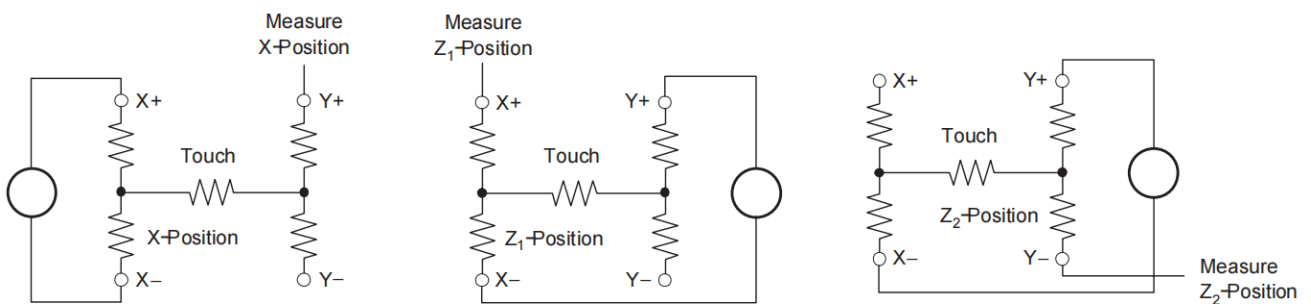

Figure 8 Pressure Measurement Block Diagrams

10. Control Byte

The control byte (on DIN), as shown in Table 3, provides the start conversion, addressing, ADC resolution, configuration, and power-down of the HT2046. Figure 9, Table 3 and Table 4 give detailed information regarding the order and description of these control bits within the control byte.

Initiate START—The first bit, the S bit, must always be high and initiates the start of the control byte. The HT2046 ignores inputs on the DIN pin until the start bit is detected.

Addressing—The next three bits (A2, A1, and A0) select the active input channel(s) of the input multiplexer (see Table 1, Table 2, and Figure 2), touch screen drivers, and the reference inputs.

MODE—The mode bit sets the resolution of the ADC. With this bit low, the next conversion has 12 bits of resolution, whereas with this bit high, the next conversion has eight bits of resolution.

SER\DFR—The SER/DFR bit controls the reference mode, either single-ended (high) or differential (low). The differential mode is also referred to as the ratiometric conversion mode and is preferred for X-Position, Y-Position, and Pressure-Touch measurements for optimum performance. The reference is derived from the voltage at the switch drivers, which is almost the same as the voltage to the touch screen. In this case, a reference voltage is not needed as the reference voltage to the ADC is the voltage across the touch screen. In the single-ended mode, the converter reference voltage is always the difference between the VREF and GND pins (see Table 1 and Table 2, and Figure 2 through Figure 5, for further information)

Table 3 Order of the Control Bits in the Control Byte

BIT 7 (MSB)	BIT 6	BIT 5	BIT 4	BIT 3	BIT 2	BIT 1	BIT 0
S	A2	A1	A0	MODE	SER\DFR	PD1	PD0

Table 4 Descriptions of the Control Bits within the Control Byte

BIT	NAME	DESCRIPTION
7	S	Start bit. Control byte starts with first high bit on DIN. A new control byte can start every 15th clock cycle in 12-bit conversion mode or every 11th clock cycle in 8-bit conversion mode (see Figure 13).
6-4	A2-A0	Channel Select bits. Along with the SER/DFR bit, these bits control the setting of the multiplexer input, touch driver switches, and reference inputs (see Table 1 and Figure 13).
3	MODE	12-Bit/8-Bit Conversion Select bit. This bit controls the number of bits for the next conversion: 12-bit (low) or 8-bits (high).
2	SER\DFR	Single-Ended/Differential Reference Select bit. Along with bits A2-A0, this bit controls the setting of the multiplexer input, touch driver switches, and reference inputs (see Table 1 and Table 2).
1-0	PD1-PD0	Power-Down Mode Select bits. Refer to Table 5 for details.

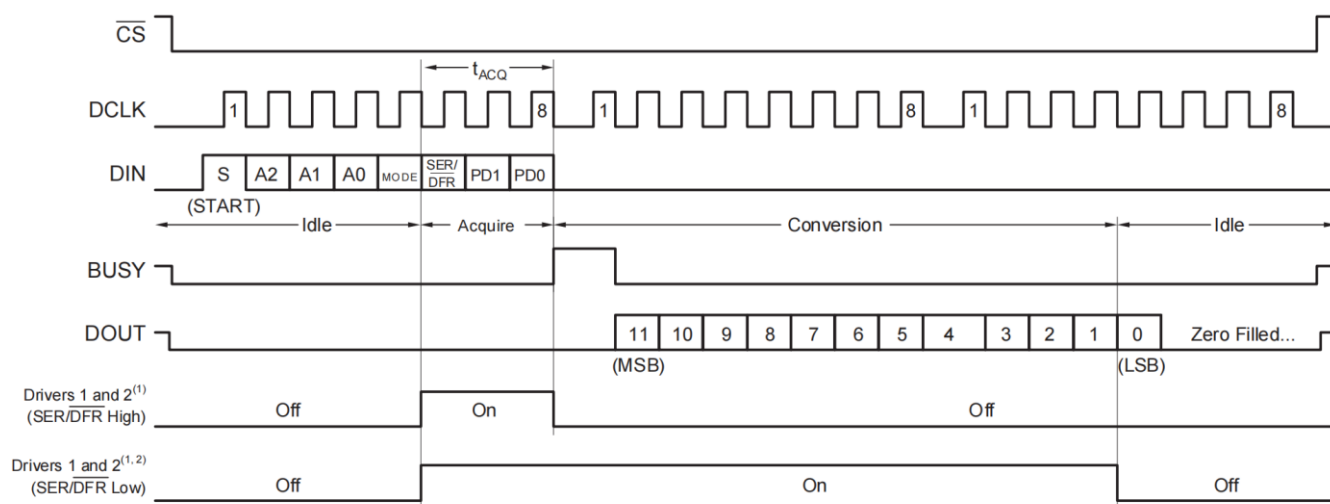

NOTES: (1) For Y-Position, Driver 1 is on X+ is selected, and Driver 2 is off. For X-Position, Driver 1 is off, Y+ is selected, and Driver 2 is on. Y- will turn on when power-down mode is entered and PD0 = 0.
 (2) Drivers will remain on if PD0 = 1 (no power down) until selected input channel, reference mode, or power-down mode is changed, or \overline{CS} is high.

Figure 9 Conversion Timing, 24 Clocks-per-Conversion, 8-Bit Bus Interface.

No DCLK delay required with dedicated serial port

If X-Position, Y-Position, and Pressure-Touch are measured in the single-ended mode, an external reference voltage is needed. The HT2046 must also be powered from the external reference. Caution should be observed when using the single-ended mode such that the input voltage to the ADC does not exceed the internal reference voltage, especially if the supply voltage is greater than 2.7V.

NOTE: The differential mode can only be used for X-Position, Y-Position, and Pressure-Touch measurements. All other measurements require the single-ended mode.

PD0 and PD1—Table 5 describes the power-down and the internal reference voltage configurations. The internal reference voltage can be turned on or off independently of the ADC. This can allow extra time for the internal reference voltage to settle to the final value prior to making a conversion. Make sure to also allow this extra wake-up time if the internal reference is powered down. The ADC requires no wake-up time and can be instantaneously used. Also note that the status of the internal reference power-down is latched into the part (internally) with BUSY going high. In order to turn the reference off, an additional write to the HT2046 is required after the channel has been converted.

Table 5 Power-Down and Internal Reference Selection

PD1	PD0	\PENIRQ	DESCRIPTION
0	0	Enabled	Power-Down Between Conversions. When each conversion is finished, the converter enters a low-power mode. At the start of the next conversion, the device instantly powers up to full power. There is no need for additional delays to ensure full operation, and the very first conversion is valid. The Y- switch is on when in power-down.
0	1	Disabled	Reference is off and ADC is on.
1	0	Enabled	Reference is on and ADC is off.
1	1	Disabled	Device is always powered. Reference is on and ADC is on.

11. \PENIRQ OUTPUT

The pen-interrupt output function is shown in Figure 10. While in power-down mode with PD0 = 0, the Y-driver is on and connects the Y-plane of the touch screen to GND. The \PENIRQ output is connected to the X+ input through two transmission gates. When the screen is touched, the X+ input is pulled to ground through the touch screen.

In the HT2046, the internal pullup resistor value is nominally 50kΩ, but this may vary between 36kΩ and 67kΩ given process and temperature variations. In order to assure a logic low of 0.35•(+VCC) is presented to the \PENIRQ circuitry, the total resistance between the X+ and Y- terminals must be less than 21kΩ. Note that the higher pullup resistance will cause a slower response time of the \PENIRQ to a screen touch, so user software should take this into account.

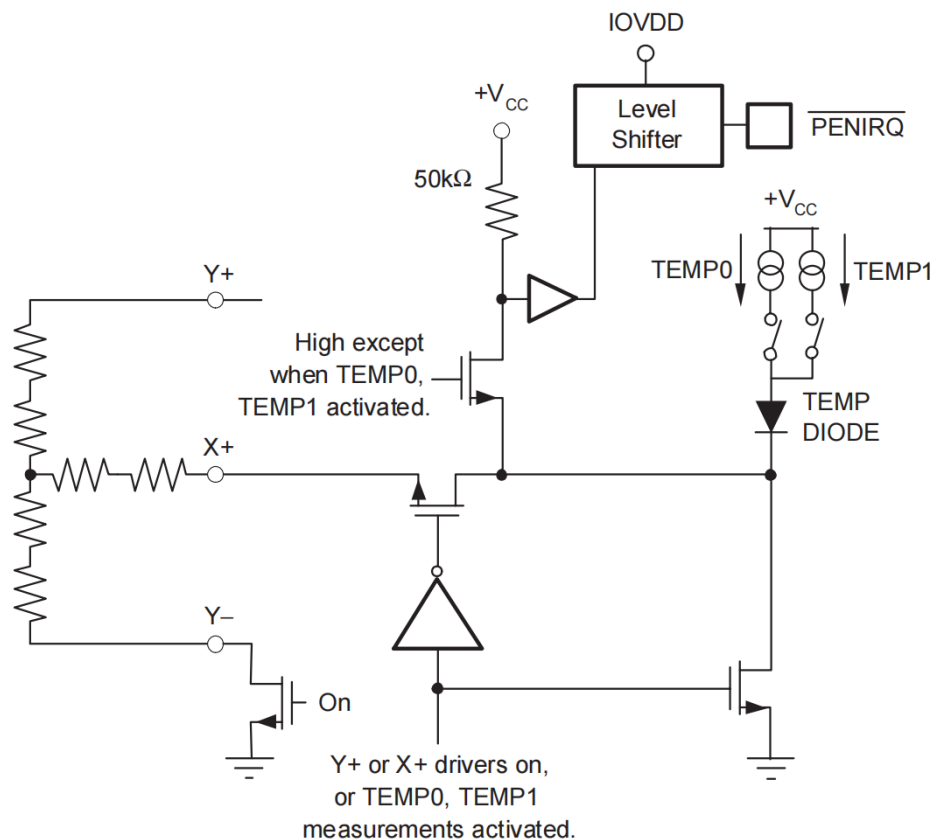

Figure 10 \PENIRQ Functional Block Diagram

The \PENIRQ output goes low due to the current path through the touch screen to ground, which initiates an interrupt to the processor. During the measurement cycle for X-, Y-, and Z-Position, the X+ input is disconnected from the \PENIRQ internal pull-up resistor. This is done to eliminate any leakage current from the internal pull-up resistor through the touch screen, thus causing no errors.

Furthermore, the \PENIRQ output is disabled and low during the measurement cycle for X-, Y-, and Z-Position. The \PENIRQ output is disabled and high during the measurement cycle for battery monitor, auxiliary input, and chip temperature. If the last control byte written to the HT2046 contains PD0 = 1, the pen-interrupt output function is disabled and is not able to detect when the screen is touched. In order to re-enable the pen-interrupt output function under these circumstances, a control byte needs to be written to the HT2046 with PD0 = 0. If the last control byte written to the HT2046 contains PD0 = 0, the pen-interrupt output function is enabled at the end of the conversion. The end of the conversion occurs on the falling edge of DCLK after bit 1 of the converted data is clocked out of the HT2046.

It is recommended that the processor mask the interrupt \PENIRQ is associated with whenever the processor sends a control byte to the HT2046. This prevents false triggering of interrupts when the \PENIRQ output is

disabled in the cases discussed in this section.

12.Clocks-per-Conversion

The control bits for conversion $n + 1$ can be overlapped with conversion n to allow for a conversion every 16 clock cycles, as shown in Figure 11. This figure also shows possible serial communication occurring with other serial peripherals between each byte transfer from the processor to the converter. This is possible, provided that each conversion completes within 1.6ms of starting. Otherwise, the signal that is captured on the input sample-and-hold may droop enough to affect the conversion result. Note that the HT2046 is fully powered while other serial communications are taking place during a conversion.

13.Digital Timing

Figure 9, Figure 12, and Table 6 provide detailed timing for the digital interface of the HT2046.

Figure 13 provides the fastest way to clock the HT2046. This method does not work with the serial interface of most microcontrollers and digital signal processors, as they are generally not capable of providing 15 clock cycles per serial transfer. However, this method can be used with field-programmable gate arrays (FPGAs) or application specific integrated circuits (ASICs). Note that this effectively increases the maximum conversion rate of the converter beyond the values given in the specification tables, which assume 16 clock cycles per conversion.

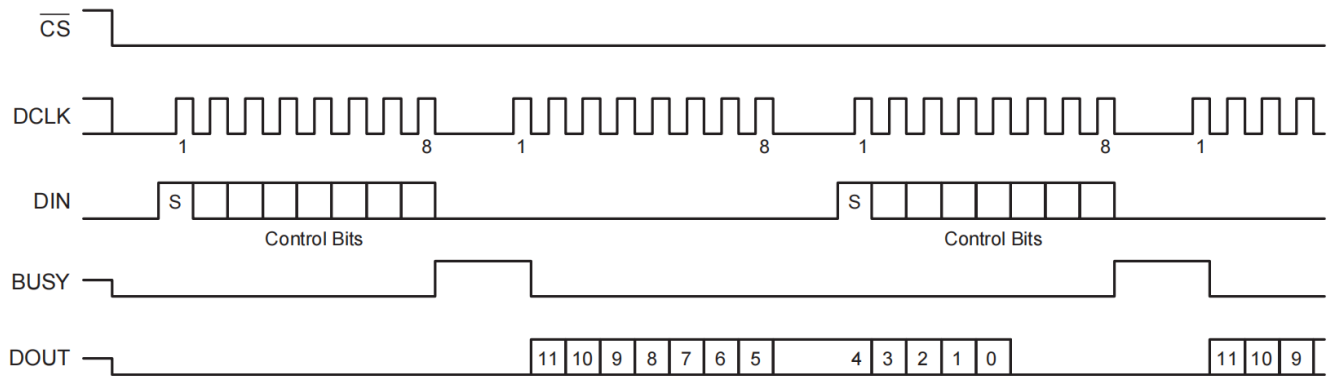

Figure 11 Conversion Timing, 16 Clocks-per-Conversion, 8-Bit Bus Interface.

No DCLK delay required with dedicated serial port

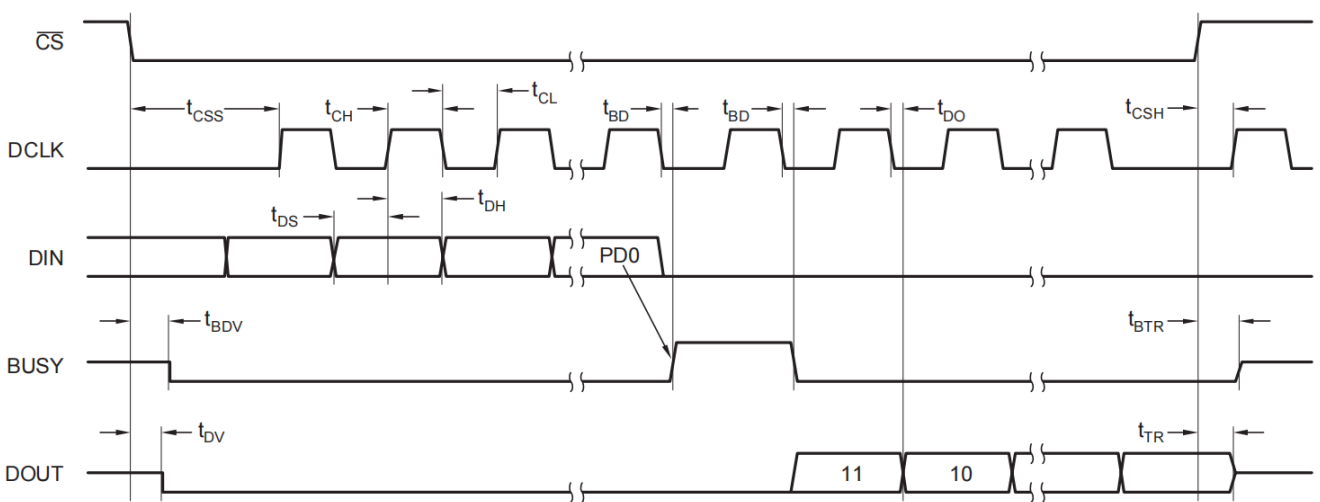

Figure 12 Detailed Timing Diagram

Table 6 Timing Specifications, $T_A = -40^{\circ}\text{C}$ to $+85^{\circ}\text{C}$

SYMBOL	DESCRIPTION	+V _{CC} • 2.7V, +V _{CC} • IOVDD • 1.5V, C _{LOAD} = 50pF			UNITS
		MIN	TYP	MAX	
t _{ACQ}	Acquisition Time	1.5			μs
t _{DS}	DIN Valid Prior to DCLK Rising	100			ns
t _{DH}	DIN Hold After DCLK High	50			ns
t _{DO}	DCLK Falling to DOUT Valid			200	ns
t _{DV}	$\overline{\text{CS}}$ Falling to DOUT Enabled			200	ns
t _{TR}	$\overline{\text{CS}}$ Rising to DOUT Disabled			200	ns
t _{CSS}	$\overline{\text{CS}}$ Falling to First DCLK Rising	100			ns
t _{CSH}	$\overline{\text{CS}}$ Rising to DCLK Ignored	10			ns
t _{CH}	DCLK High	200			ns
t _{CL}	DCLK Low	200			ns
t _{BD}	DCLK Falling to BUSY Rising/Falling			200	ns
t _{BDV}	$\overline{\text{CS}}$ Falling to BUSY Enabled			200	ns
t _{BTR}	$\overline{\text{CS}}$ Rising to BUSY Disabled			200	ns

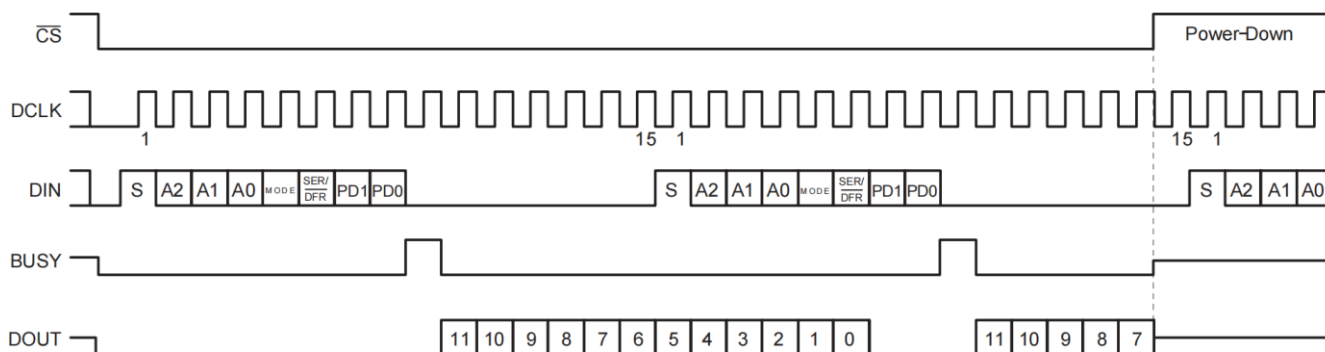

Figure 13 Maximum Conversion Rate, 15 Clocks-per-Conversion

14. Digital Timing

The HT2046 output data is in Straight Binary format, as shown in Figure 14. This figure shows the ideal output code for the given input voltage and does not include the effects of offset, gain, or noise.

15.8-Bit Conversion

The HT2046 provides an 8-bit conversion mode that can be used when faster throughput is needed and the digital result is not as critical. By switching to the 8-bit mode, a conversion is complete four clock cycles earlier. Not only does this shorten each conversion by four bits (25% faster throughput), but each conversion can actually occur at a faster clock rate. This is because the internal settling time of the HT2046 is not as critical—settling to better than 8 bits is all that is needed. The clock rate can be as much as 50% faster. The faster clock rate and fewer clock cycles combine to provide a 2x increase in conversion rate.

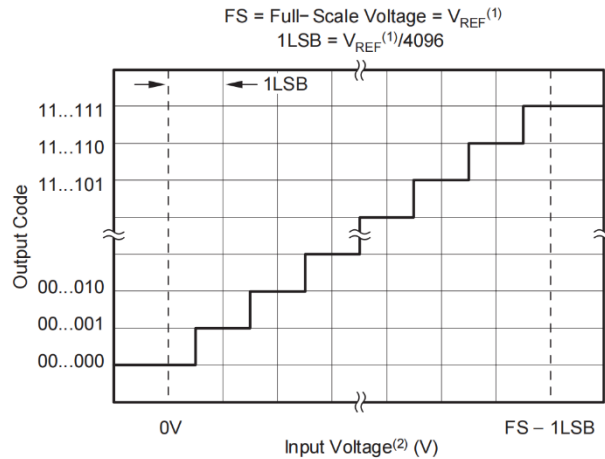

NOTES: (1) Reference voltage at converter: +REF - (-REF); see Figure 2.
(2) Input voltage at converter, after multiplexer: +IN - (-IN); see Figure 2.

Figure 14 Ideal Input Voltages and Output Codes

16. POWER DISSIPATION

There are two major power modes for the HT2046: full-power (PD0 = 1) and auto power-down (PD0 = 0). When operating at full speed and 16 clocks-per-conversion (see Figure 11), the HT2046 spends most of the time acquiring or converting. There is little time for auto power-down, assuming that this mode is active. Therefore, the difference between full-power mod and auto power-down is negligible. If the conversion rate is decreased by slowing the frequency of the DCLK input, the two modes remain approximately equal. However, if the DCLK frequency is kept at the maximum rate during a conversion but conversions are done less often, the difference between the two modes is dramatic.

Figure 15 shows the difference between reducing the DCLK frequency (scaling DCLK to match the conversion rate) or maintaining DCLK at the highest frequency and reducing the number of conversions per second. In the latter case, the converter spends an increasing percentage of time in power-down mode (assuming the auto power-down mode is active).

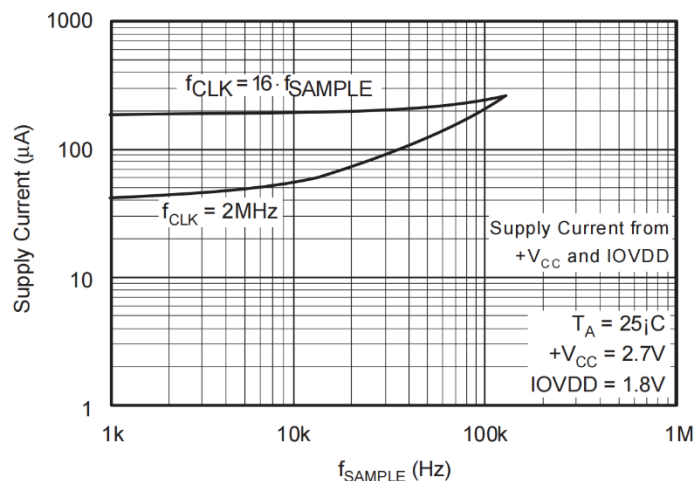

Figure 15 Supply Current versus Directly Scaling the Frequency of DCLK with Sample Rate or Maintaining DCLK at the Maximum Possible Frequency

Another important consideration for power dissipation is the reference mode of the converter. In the single-ended reference mode, the touch panel drivers are ON only when the analog input voltage is being acquired (see Figure 9 and Table 1). The external device (e.g., a resistive touch screen), therefore, is only powered during the acquisition period. In the differential reference mode, the external device must be powered throughout the acquisition and conversion periods (see Figure 9). If the conversion rate is high, this could

substantially increase power dissipation.

\CS also puts the HT2046 into power-down mode. When \CS goes high, the HT2046 immediately goes into power-down mode and does not complete the current conversion. The internal reference, however, does not turn off with \CS going high. To turn the reference off, an additional write is required before \CS goes high (PD1 = 0).

When the HT2046 first powers up, the device draws about 20 μ A of current until a control byte is written to it with PD0 = 0 to put it into power-down mode. This can be avoided if the HT2046 is powered up with \CS = 0 and DCLK = IOVDD.

17.LAYOUT

The following layout suggestions provide the most optimum performance from the HT2046. Many portable applications, however, have conflicting requirements concerning power, cost, size, and weight. In general, most portable devices have fairly clean power and grounds because most of the internal components are very low power. This situation means less bypassing for the converter power and less concern regarding grounding. Still, each situation is unique and the following suggestions should be reviewed carefully.

For optimum performance, care should be taken with the physical layout of the HT2046 circuitry. The basic SAR architecture is sensitive to glitches or sudden changes on the power supply, reference, ground connections, and digital inputs that occur just prior to latching the output of the analog comparator. Therefore, during any single conversion for an n-bit SAR converter, there are n 'windows' in which large external transient voltages can easily affect the conversion result. Such glitches can originate from switching power supplies, nearby digital logic, and high-power devices. The degree of error in the digital output depends on the reference voltage, layout, and the exact timing of the external event. The error can change if the external event changes in time with respect to the DCLK input.

With this in mind, power to the HT2046 should be clean and well bypassed. A 0.1 μ F ceramic bypass capacitor should be placed as close to the device as possible. A 1 μ F to 10 μ F capacitor may also be needed if the impedance of the connection between +VCC or IOVDD and the power supplies is high. Low-leakage capacitors should be used to minimize power dissipation through the bypass capacitors when the HT2046 is in power-down mode.

A bypass capacitor is generally not needed on the VREF pin because the internal reference is buffered by an internal op amp. If an external reference voltage originates from an op amp, make sure that it can drive any bypass capacitor that is used without oscillation.

The HT2046 architecture offers no inherent rejection of noise or voltage variation in regards to using an external reference input. This is of particular concern when the reference input is tied to the power supply. Any noise and ripple from the supply appears directly in the digital results. Whereas high-frequency noise can be filtered out, voltage variation due to line frequency (50Hz or 60Hz) can be difficult to remove.

The GND pin must be connected to a clean ground point. In many cases, this is the analog ground. Avoid connections which are too near the grounding point of a microcontroller or digital signal processor. If needed, run a ground trace directly from the converter to the power-supply entry or battery connection point. The ideal layout includes an analog ground plane dedicated to the converter and associated analog circuitry.

In the specific case of use with a resistive touch screen, care should be taken with the connection between the converter and the touch screen. Although resistive touch screens have fairly low resistance, the interconnection should be as short and robust as possible. Longer connections are a source of error, much like the on-resistance of the internal switches. Likewise, loose connections can be a source of error when the contact resistance changes with flexing or vibrations.

As indicated previously, noise can be a major source of error in touch screen applications (e.g., applications that require a backlit LCD panel). This EMI noise can be coupled through the LCD panel to the touch screen and cause flickering of the converted data. Several things can be done to reduce this error, such as using a touch screen with a bottom-side metal layer connected to ground to shunt the majority of noise to ground. Additionally, filtering capacitors from Y+, Y-, X+, and X- pins to ground can also help. Caution should be

observed under these circumstances for settling time of the touch screen, especially operating in the single-ended mode and at high data rates.

PACKAGE OUTLINE

COMMON DIMENSIONS
(UNITS OF MEASURE=MILLIMETER)

SYMBOL	MIN	TYP	MAX
A	0.70	0.75	0.80
A1	0.00	0.02	0.05
A2		0.20	
b	0.25	0.30	0.35
D	3.90	4.00	4.10
D1	2.10	2.20	2.30
E	3.90	4.00	4.10
E1	2.10	2.20	2.30
e		0.65BSC	
L	0.50	0.55	0.60
N		16	
aaa		0.08	
bbb		0.10	

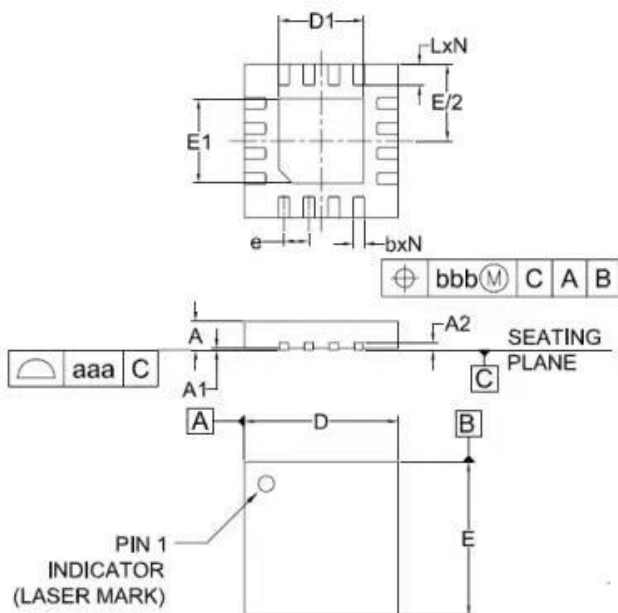

IMPORTANT NOTICE
注意

Jiaxing Heroic Electronic Technology Co., Ltd (HT) reserves the right to make corrections, modifications, enhancements, improvements, and other changes to its products and services at any time and to discontinue any products or services. Customers should obtain the latest relevant information before placing orders and should verify that such information is current and complete.

嘉兴禾润电子科技有限公司（以下简称HT）保留对产品、服务、文档的任何修改、更正、提高、改善和其他改变，或停止提供任何产品和服务的权利。客户在下单和生产前应确保所得到的信息是最新、最完整的。

HT assumes no liability for applications assistance or customer product design. Customers are responsible for their products and applications using HT components.

HT对相关应用的说明和协助以及客户产品的板级设计不承担任何责任。

HT products are not authorized for use in safety-critical applications (such as life support devices or systems) where a failure of the HT product would reasonably be expected to affect the safety or effectiveness of that devices or systems.

HT的产品并未授权用于诸如生命维持设备等安全性极高的应用中。

The information included herein is believed to be accurate and reliable. However, HT assumes no responsibility for its use; nor for any infringement of patents or other rights of third parties which may result from its use.

本文中的相关信息是精确和可靠的，但HT并不对其负责，也不对任何可能的专利和第三方权利的侵害负责。

Following are URLs and contacts where you can obtain information or supports on any HT products and application solutions:

下面是可以联系到我公司的相关链接和联系方式：

嘉兴禾润电子科技有限公司**Jiaxing Heroic Electronic Technology Co., Ltd.**

地址: 浙江省嘉兴市凌公塘路3339号JRC大厦A座三层

Add: A 3rd floor, JRC Building, No. 3339, LingGongTang Road, Jiaxing, Zhejiang Province

Sales: 0573-82585539, sales@heroic.com.cn

Support: 0573-82586151, support@heroic.com.cn

Fax: 0573-82585078

Website: www.heroic.com.cn; wap.heroic.com.cn

Wechat MP: HEROIC_JX

请及时关注禾润官方微信公众号，随时获取最新产品信息和技术资料！

